

Performance curves

UPS 80-40/4
3 phase 208-230 V, 460 V, 575 V★, 60 Hz

Performance curves

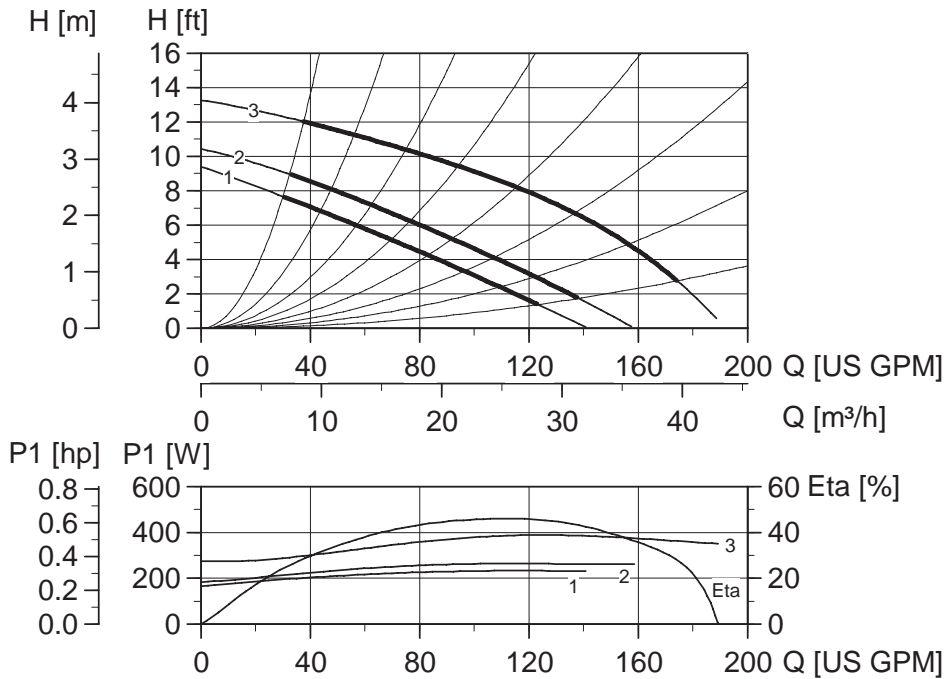

Note: ETA is calculated as wire-to-water efficiency.

Weights and volume

	Cast Iron				Bronze			
	lbs.	ft ³	Kg	m ³	lbs.	ft ³	Kg	m ³
Net weight	78.7		35.7		91.9		41.7	
Gross weight	91.1		41.3		104.3		47.3	
Shipping volume		2.90		0.082		2.90		0.082

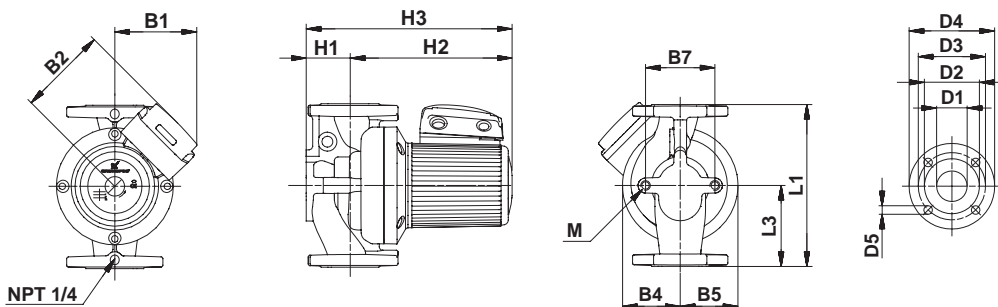

Dimensions

	L1	L3	B1	B2	B4	B5	B7	H1	H2	H3	D1	D2	D3	D4	D5	M
[Inches]	19	9 1/2	5 3/4	6 11/16	4 15/16	3 15/16	6 5/16	3 13/16	9 7/16	13 1/8	3 3/16	5	6	7 9/16	3/4	
[mm]	482.6	241.3	145	169	125	100	160	97	240	337	81	127	152	191	19	M16

★Canada only

TM00 9506 0697

TM02 0731 5100