

Performance curves

UPS 75-69
3 phase 208-230 V, 460 V, 575 V★, 60 Hz

Performance curves

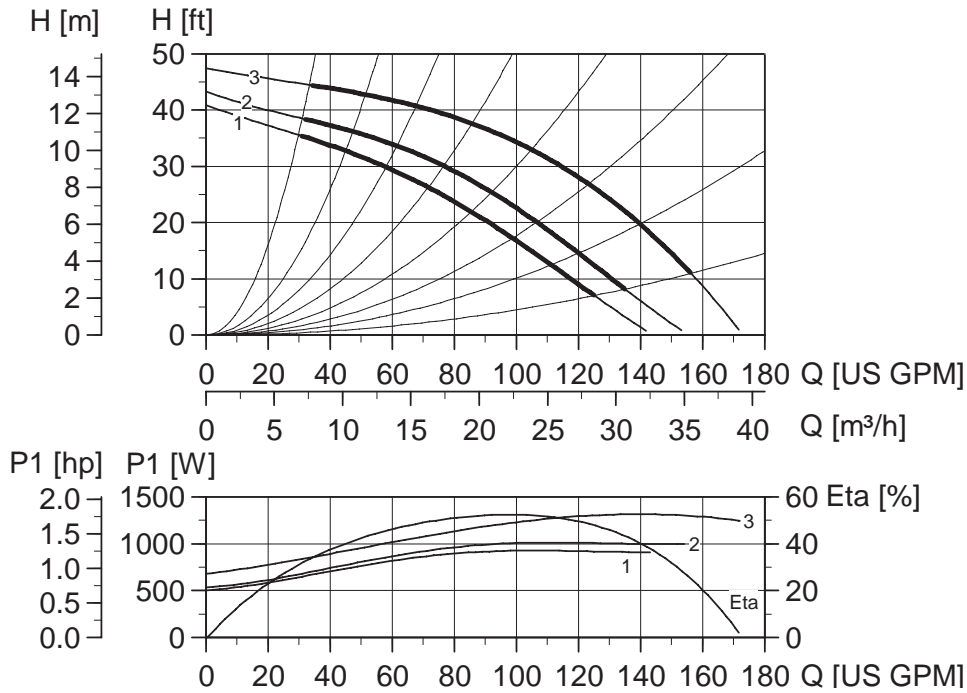

Note: ETA is calculated as wire-to-water efficiency.

Weights and volume

	Cast Iron				Bronze			
	lbs.	ft ³	Kg	m ³	lbs.	ft ³	Kg	m ³
Net weight	53.6		24.3		68.3		31	
Gross weight	65.7		29.8		80.5		36.5	
Shipping volume		3.5		0.098		3.5		0.098

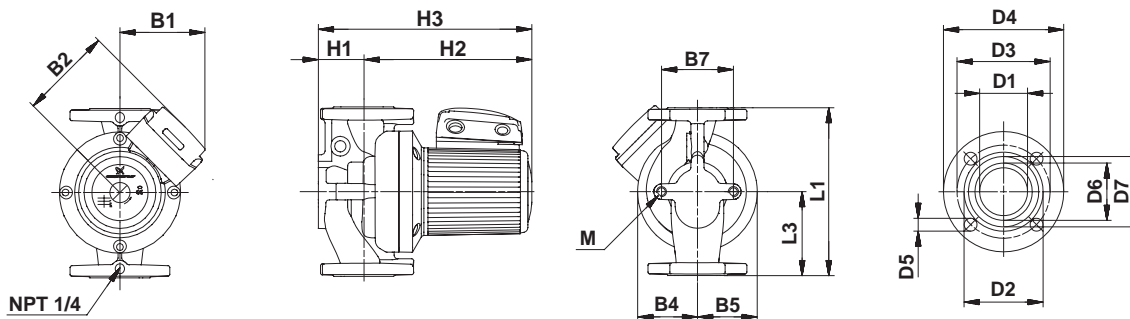

Dimensions

	L1	L3	B1	B2	B4	B5	B7	H1	H2	H3	D1	D2	D3	D4	D5	D6	D7	M
[Inches]	14 1/4	7 1/8	5 11/16	6 5/8	3 15/16	3 15/16	4 1/2	2 15/16	10 13/16	13 1/2	2 15/16	4 5/16	6	7 1/2	12/16	3 1/2	4	
[mm]	362	181	145	169	100	100	120	75	274	349	75	110	152	190	19	89	101	M12

★Canada only