

Performance curves

UPS 53-55/57
3 phase 208-230 V, 460 V, 575 V★, 60 Hz

Performance curves

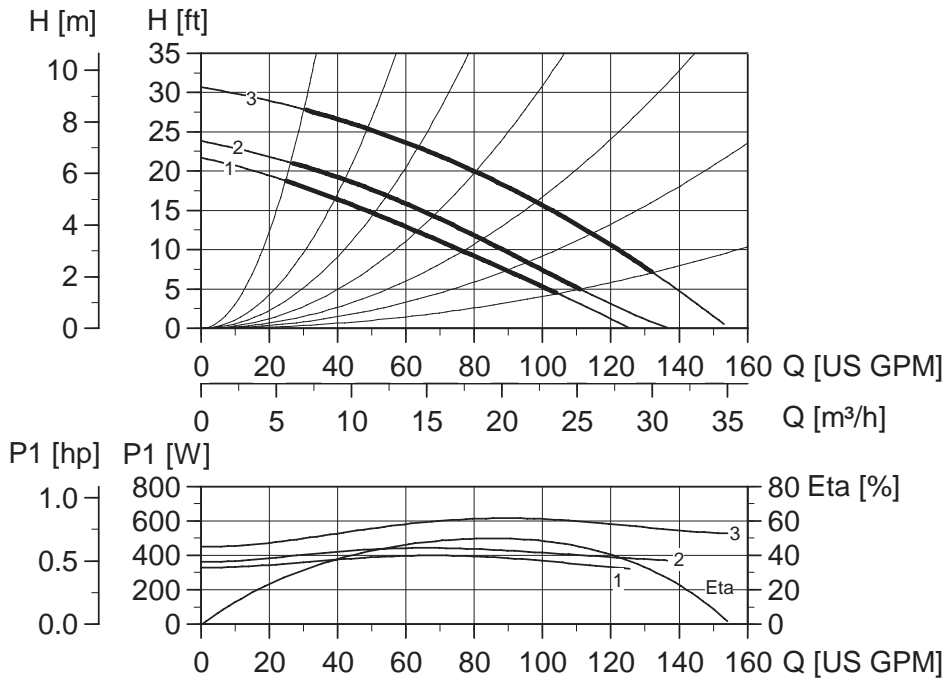

Note: ETA is calculated as wire-to-water efficiency.

Weights and volume

	Cast Iron				Bronze			
	lbs.	ft ³	Kg	m ³	lbs.	ft ³	Kg	m ³
Net weight	46.7		21.2		52.2		23.7	
Gross weight	54.2		24.6		59.7		27.1	
Shipping volume		2.1		0.06		2.1		0.06

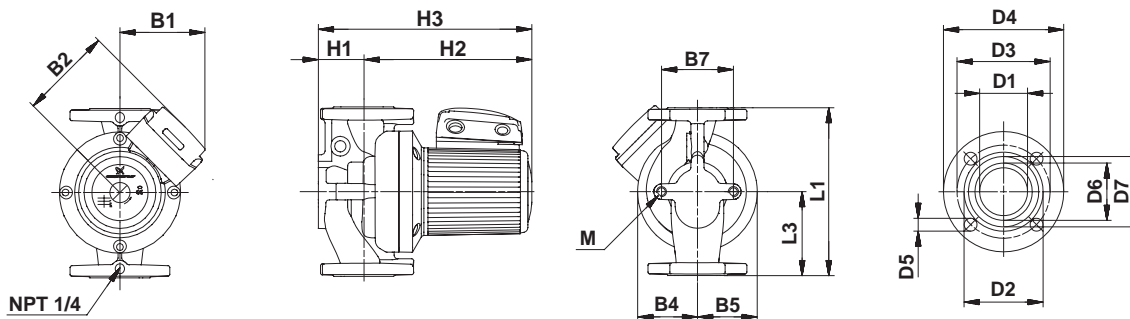

Dimensions

	L1	L3	B1	B2	B4	B5	B7	H1	H2	H3	D1	D2	D3	D4	D5	D6	D7	M
[Inches]	11 7/8	5 15/16	5 5/16	5 9/16	3 3/4	2 15/16	4 3/4	2 15/16	9 14/16	12 13/16	2 1/16	4 3/16	5	6	5/8	3 1/2	4	
[mm]	302	151	135	141	95	75	120	75	251	326	53	106	127	152	16	89	101	M12

★Canada only