

TM04 7918 2410

Flow range: 120 gpm
 Head range: 21 feet
 Motors: 2-pole, single-phase
 Max. liquid temperature: 230 °F (110 °C)
 Min. liquid temperature: 36 °F (10 °C)
 Max. system pressure: 145 psi (10 bar)
 Closed or Open system

Model	Spd	Volts	Amps	Watts	Hp	Capacitor
UPS 50-60 F/SF	3		3.6	395	1/6	40µF/180V
	2	115	3.4	350	1/6	
	1		2.7	260	1/6	
UPS 50-60 F/SF	3		1.9	395	1/6	10µF/400V
	2	208	1.7	350	1/6	
	1		1.4	290	1/6	
	3		1.8	395	1/6	
	2	230	1.7	350	1/6	
	1		1.4	260	1/6	

UPS 50-60 F/SF

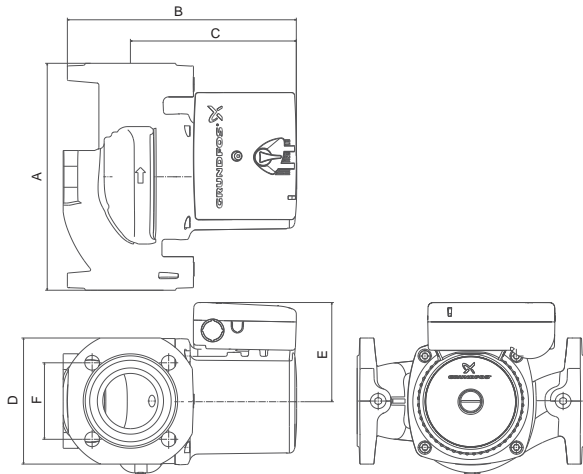

TM04 9775 0111

Approvals



Model type	Product number		Dimensions [inches]						Connection type and size	Shipping weight [lbs]
	115 V	208 - 230 V	A	B	C	D	E	F		
UPS 50-60 F	97523134	—								20
UPS 50-60 F	—	97523135	8 1/2	8 5/8	6 1/4	4 3/4	3 3/4	2 7/8	GF 50	20
UPS 50-60 SF	97523136	—								19.5
UPS 50-60 SF	—	97523137								19.5

Note: Dimensions in inches unless otherwise noted.