

Performance curves

UPS 40-80/4
1 phase 115 V, 230 V, 60 Hz

Performance curves

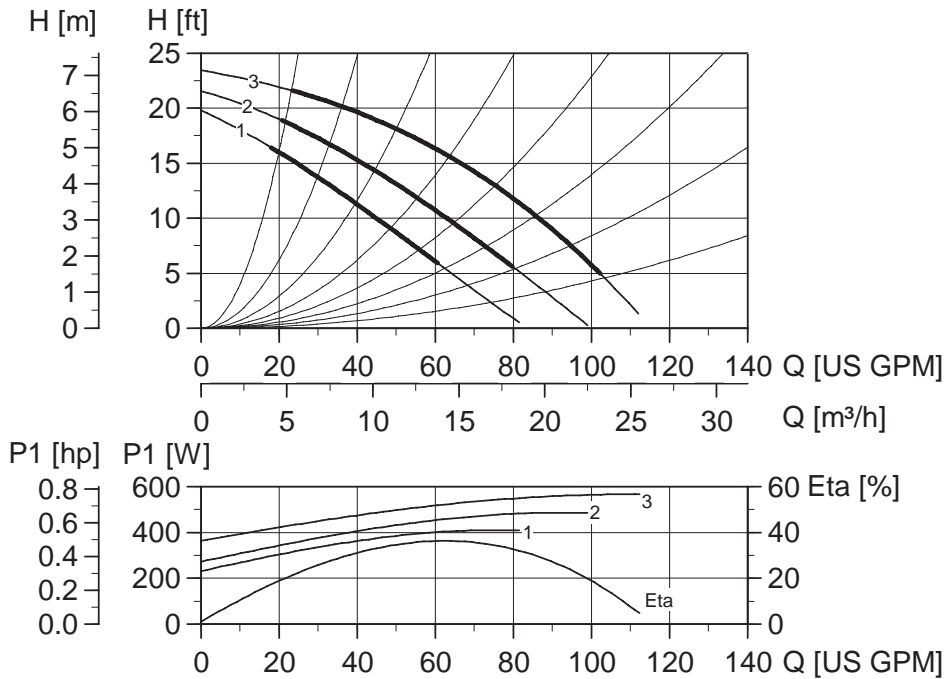

Note: ETA is calculated as wire-to-water efficiency.

Weights and volume

	Cast Iron				Bronze			
	lbs.	ft ³	Kg	m ³	lbs.	ft ³	Kg	m ³
Net weight	57.8		26.2		62.2		28.2	
Gross weight	70.1		31.8		74.5		33.8	
Shipping volume		2.90		0.082		2.90		0.082

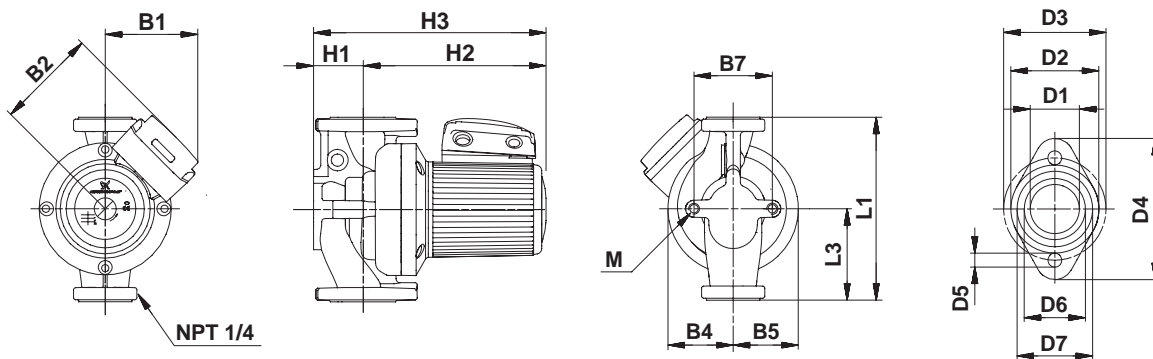

Dimensions

	L1	L3	B1	B2	B4	B5	B7	H1	H2	H3	D1	D2	D3	D4	D5	D6	D7	M
[Inches]	13 1/2	6 3/4	5 3/4	6 5/8	3 15/16	3 15/16	4 3/4	3	9	13 3/16	1 11/16	2 7/8	3 7/16	5	1/2	2 1/16	2 9/16	
[mm]	343	171.5	145	169	100	100	120	75	228	335	41.8	73	87	127	12	52	64.6	M12