

# Performance curves

UPS 40-80/2  
3 phase 208-230 V, 460 V, 575 V★, 60 Hz

## Performance curves

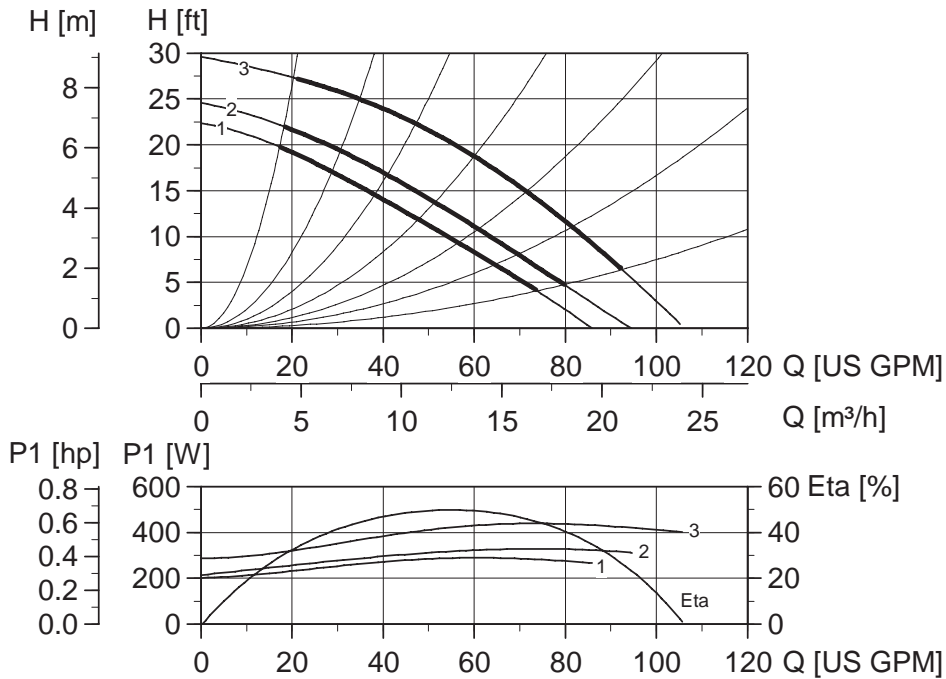

Note: ETA is calculated as wire-to-water efficiency.

## Weights and volume

|                 | Cast Iron |                 |      |                | Bronze |                 |      |                |
|-----------------|-----------|-----------------|------|----------------|--------|-----------------|------|----------------|
|                 | lbs.      | ft <sup>3</sup> | Kg   | m <sup>3</sup> | lbs.   | ft <sup>3</sup> | Kg   | m <sup>3</sup> |
| Net weight      | 38.4      |                 | 17.4 |                | 42.8   |                 | 19.4 |                |
| Gross weight    | 46.5      |                 | 21.1 |                | 50.9   |                 | 23.1 |                |
| Shipping volume |           | 1.70            |      | 0.048          |        | 1.70            |      | 0.048          |

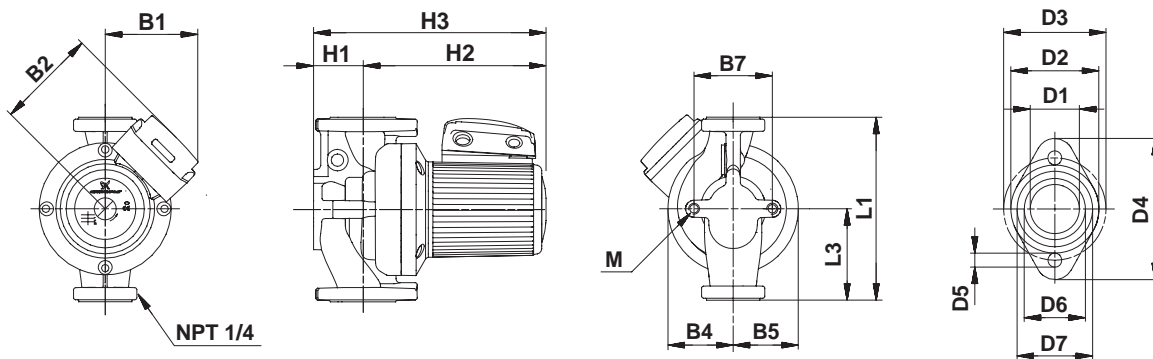

## Dimensions

|          | L1     | L3    | B1     | B2     | B4 | B5 | B7    | H1      | H2    | H3      | D1      | D2    | D3     | D4  | D5  | D6     | D7     | M   |
|----------|--------|-------|--------|--------|----|----|-------|---------|-------|---------|---------|-------|--------|-----|-----|--------|--------|-----|
| [Inches] | 13 1/2 | 6 3/4 | 5 5/16 | 5 9/16 | 3  | 3  | 3 1/8 | 2 11/16 | 9 5/8 | 12 5/16 | 1 11/16 | 2 7/8 | 3 7/16 | 5   | 1/2 | 2 1/16 | 2 9/16 |     |
| [mm]     | 342.9  | 171.5 | 135    | 141    | 75 | 75 | 80    | 68      | 245   | 315     | 41.8    | 73    | 87     | 127 | 12  | 52     | 64.6   | M12 |

★Canada only

TM00 9497 0697

TM02 0729 5100