

# Performance curves

UPS 40-40/4  
3 phase 208-230 V, 460 V, 575 V★, 60 Hz

## Performance curves

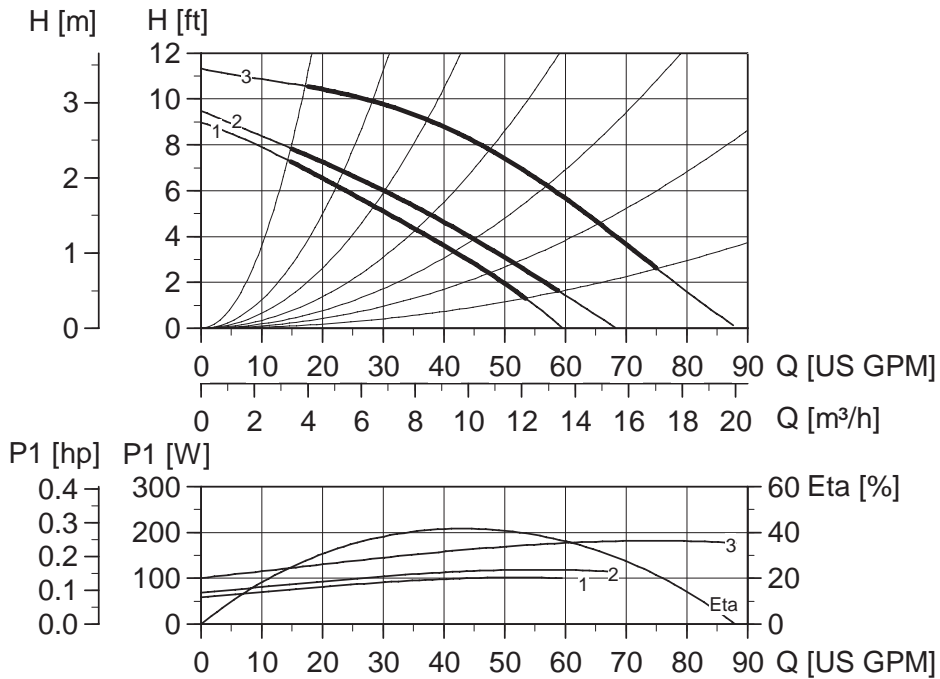

Note: ETA is calculated as wire-to-water efficiency.

## Weights and volume

	Cast Iron				Bronze			
	lbs.	ft <sup>3</sup>	Kg	m <sup>3</sup>	lbs.	ft <sup>3</sup>	Kg	m <sup>3</sup>
Net weight	37.7		17.1		42.1		19.1	
Gross weight	45.9		20.8		50.3		22.8	
Shipping volume		1.70		0.048		1.70		0.048

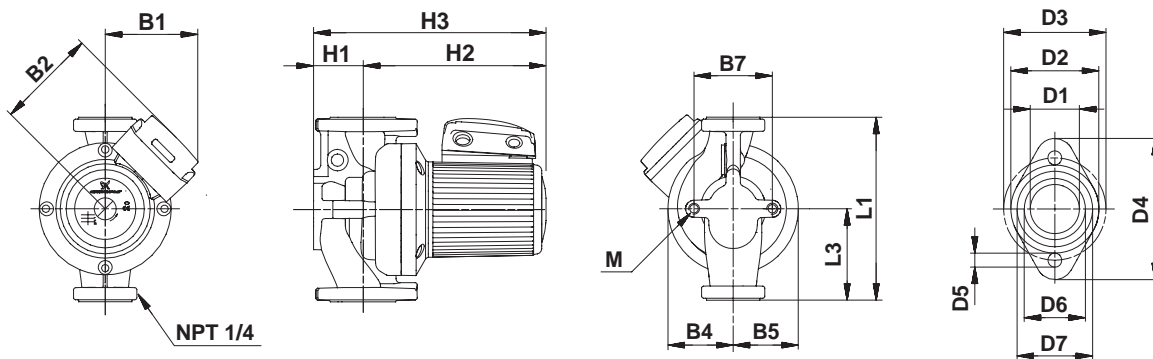

## Dimensions

	L1	L3	B1	B2	B4	B5	B7	H1	H2	H3	D1	D2	D3	D4	D5	D6	D7	M
[Inches]	13 1/2	6 3/4	5 5/16	5 9/16	3	3	4 3/4	2 11/16	9 11/16	12 3/8	1 5/8	2 7/8	3 7/16	5	1/2	2 1/16	2 9/16	
[mm]	343	171.5	135	141	85	75	120	68	246	314	41.8	73	87	127	12	52	64.6	M12

★Canada only

TM00 9496 0697

TM02 0729 5100