

Performance curves

UPS 40-240/2
1 phase 230 V, 60 Hz

Performance curves

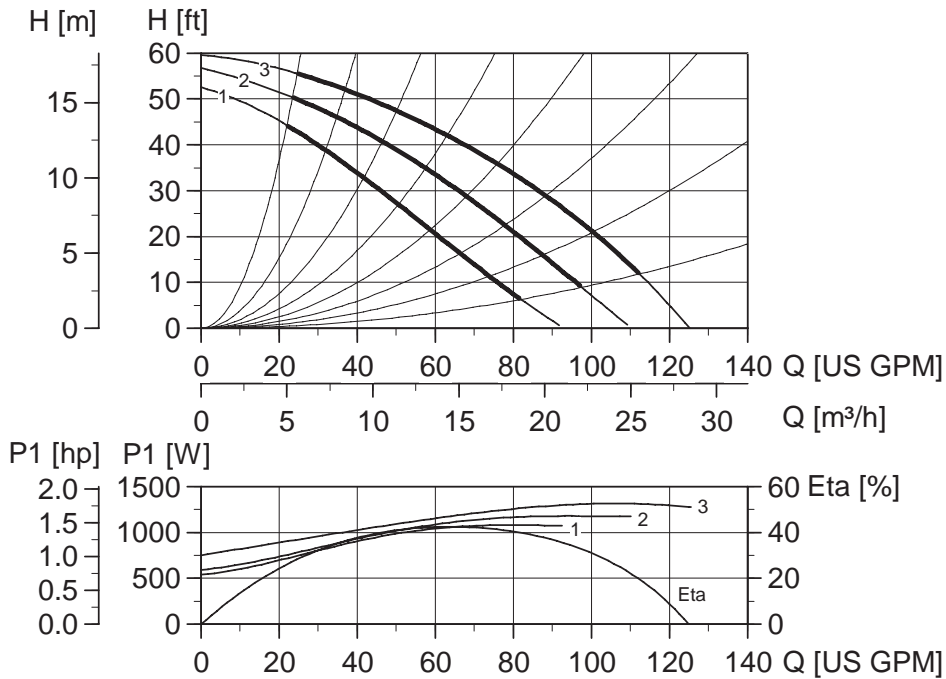

Note: ETA is calculated as wire-to-water efficiency.

Weights and volume

	Cast Iron				Bronze			
	lbs.	ft ³	Kg	m ³	lbs.	ft ³	Kg	m ³
Net weight	54.0		24.5		58.4		26.5	
Gross weight	66.4		30.1		70.8		32.1	
Shipping volume		2.90		0.082		2.90		0.082

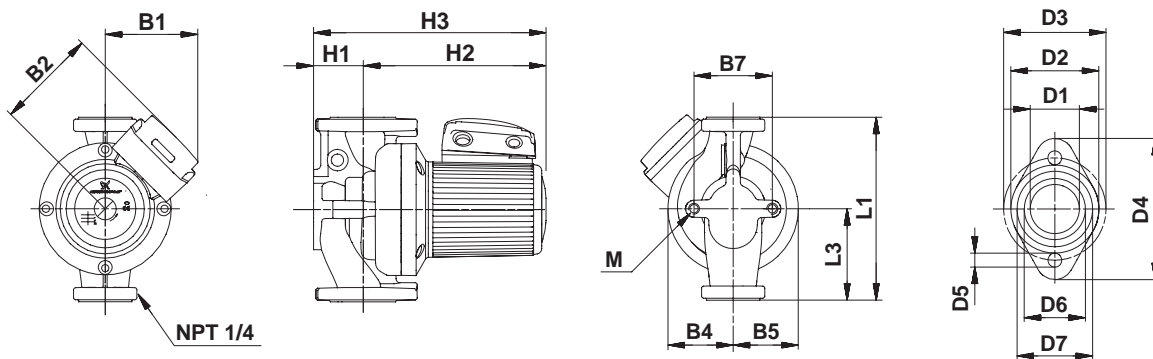

Dimensions

	L1	L3	B1	B2	B4	B5	B7	H1	H2	H3	D1	D2	D3	D4	D5	D6	D7	M
[Inches]	13 1/2	6 3/4	5 3/4	6 5/8	4	4	3 3/16	2 11/16	11 1/16	13 3/4	1 11/16	2 7/8	3 7/16	5	1/2	2 1/16	2 9/16	
[mm]	342.9	171.5	145	169	100	100	80	68	281	349	41.8	73	87	127	12	52	64.6	M12