

Performance curves

UPS 32-80/2
3 phase 208-230 V, 460 V, 575 V★, 60 Hz

Performance curves

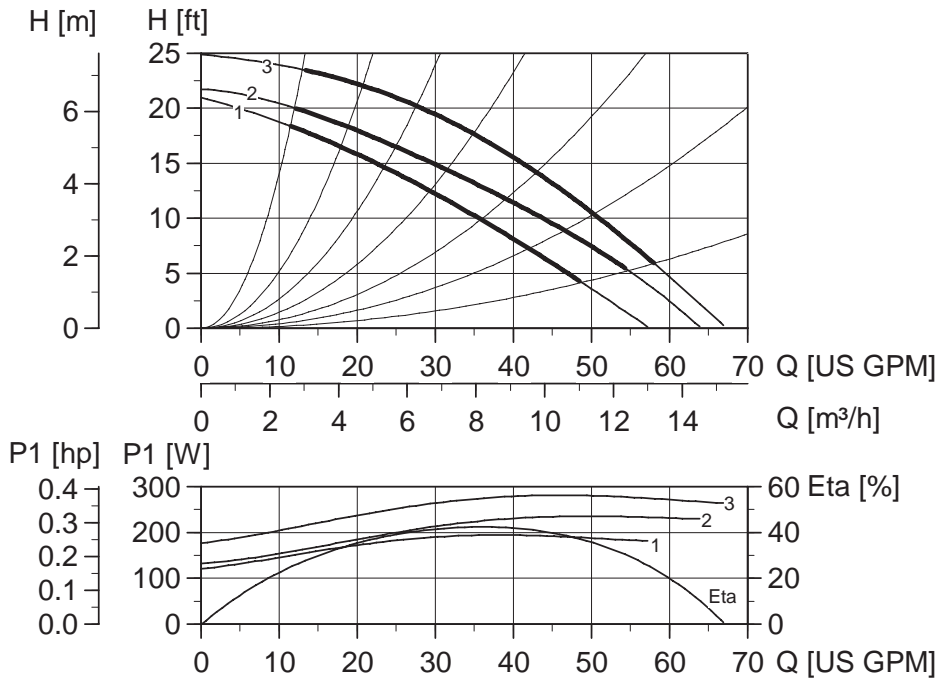

Note: ETA is calculated as wire-to-water efficiency.

Weights and volume

	Cast Iron				Bronze			
	lbs.	ft ³	Kg	m ³	lbs.	ft ³	Kg	m ³
Net weight	35.9		16.3		39.2		17.8	
Gross weight	44.1		20		47.4		21.5	
Shipping volume		1.70		0.048		1.70		0.048

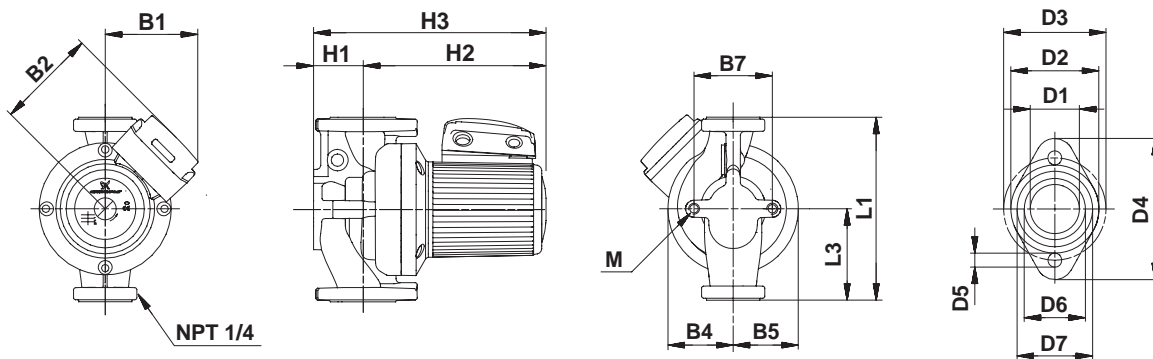

Dimensions

	L1	L3	B1	B2	B4	B5	B7	H1	H2	H3	D1	D2	D3	D4	D5	D6	D7	M
[Inches]	11	5 1/2	5 5/16	5 9/16	3	3	3 3/16	2 11/16	9 7/16	12 1/16	1 7/16	2 9/16	3 7/16	4 5/8	1/2	1 13/16	2 1/4	
[mm]	279.4	139.7	135	141	75	75	80	68	239	307	35.9	64	80	117	12	46	57	M12

★Canada only

TM00 9494 0697

TM02 0729 5100