

Centrifugal Roof Downblast Exhaust Fans

- General Clean Air
- Light Contaminants
- Seismic
- High Wind

Models GB

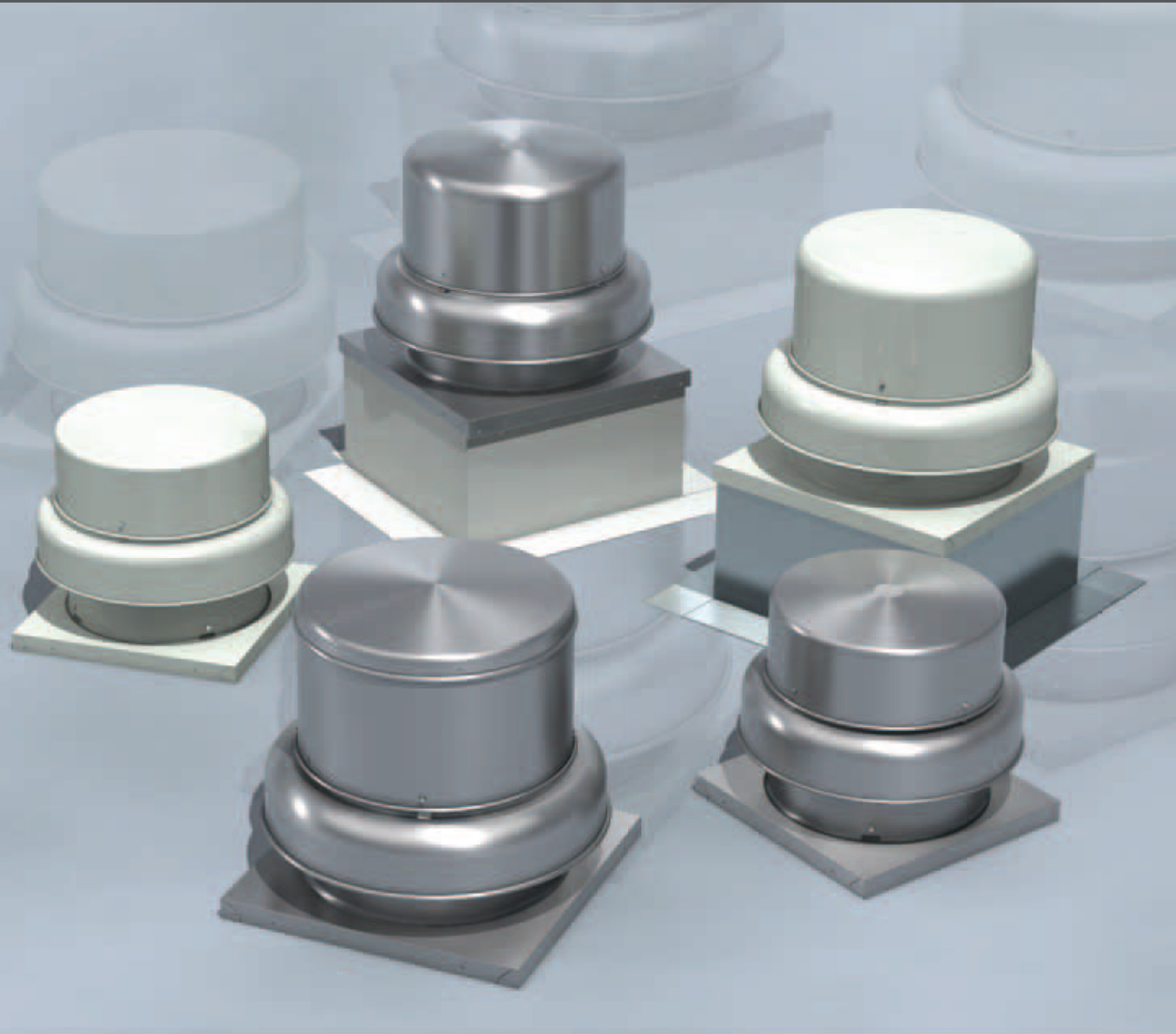

BUILDING VALUE IN AIR.

 **GREENHECK**
Building Value in Air.

July
2009

Centrifugal Roof Exhaust Fans

Spun Aluminum • Downblast



Greenheck models G and GB centrifugal roof exhaust fans provide the industry's best performance and durability for general clean air applications.

- Broadest performance in the industry, up to 3.25 in. wg (810 Pa) and 45,000 cfm (76,500 m³/hr).
- Most advanced motor cooling of any fan in its class.
- Performance as cataloged is assured. All fan sizes are tested in our AMCA Accredited Laboratory, and all models are licensed to bear the AMCA sound and air performance seals.
- UL Listed for electrical.*
- Greenheck subjects these products to extensive life testing, assuring you that the fans will provide years of reliable performance.



Greenheck Fan Corporation certifies that the Models G, and GB fans shown herein are licensed to bear the AMCA Seal. The ratings shown are based on tests and procedures performed in accordance with AMCA Publication 211 and Publication 311 and comply with the requirements of the AMCA Certified Ratings Program. The certified ratings for Models G, and GB are shown on pages 17 to 55.



G and GB models are listed for electrical (UL/cUL 705) File no. E40001

**UL/cUL is optional and must be specified*

Model Comparison

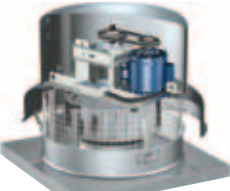
Model		Mounting	Airflow	Application			Drive Type		Performance	
		Roof Curb	Exhaust	General/Clean Air	Maximum Operating Temperature	High Wind (150 mph)	Belt	Direct	Maximum Volume cfm (m ³ /hr)	Maximum Static Pressure in. wg (Pascals)
	G	✓	✓	✓	130°F (54°C)	✓		✓	4,300 (7,306)	1.0 (249)
	GB	✓	✓	✓	180°F (82°C)	✓	✓		44,700 (75,946)	3.25 (810)

Standard Construction Features		G and GB
Wheel	An aluminum, backward-inclined, non-overloading centrifugal wheel is utilized to generate high-efficiency and minimal sound. Wheel cones are carefully matched to the venturi for maximum efficiency. Each wheel is robotically welded and statically and dynamically balanced for long life and quiet operation.	✓
Disconnect Switch	NEMA-1 switch is factory mounted and wiring is provided from the motor as standard (other switches are available). All wiring and electrical components comply with the National Electric Code (NEC) and are either UL Listed or Recognized.	✓
Fan Shaft	Precisely sized, ground and polished so the first critical speed is at least 25% over the maximum operating speed. Where the shaft makes contact with bearings, close tolerances result in longer bearing life.	✓
Bearings	100% factory tested and designed specifically for air handling applications with a minimum L ₁₀ life in excess of 100,000 hours (L ₅₀ life of 500,000 hours).	✓
Motor	Carefully matched to the fan load and is mounted out of the airstream.	✓
Motor Cover	Constructed of aluminum, machine-punched, and attached with stainless steel hardware for easy removal and access to motor compartment and drive assembly.	✓
Motor Cooling	Cooling fins located on top of the fan wheel draw outside air through a large space between the fan shroud and the motor cover directly into the motor compartment. Positive motor cooling with fresh air results in maximum motor life.	✓
Lifting Points	Various lifting points are located on the drive frame and bearing plate (on select sizes).	✓
True Vibration Isolation	Vibration isolators, with no metal-to-metal contact, support the drive assembly and wheel for long life and quiet operation.	✓
Drive Assembly	Belts, pulleys, and keys are oversized 150% of driven horsepower. Machined cast pulleys are adjustable for final system balancing. Belts are static-free and oil-resistant.	✓
Lower Windband	Heavy-gauge aluminum with formed edges for added strength and provides weather resistance.	✓
Curb Cap	Curb cap (with integral deep spun venturi) is constructed of aluminum and is one-piece for a weather-tight fit.	✓
Internal Conduit Chase	A large diameter conduit for installing electrical wiring through the curb cap into the motor compartment.	✓
Nameplate	Permanent stamped aluminum plate for exact model and serial number identification.	✓
Galvanized Birdscreen	Rigid wire protects the fan discharge from birds and small objects.	✓
Fan Shroud	One-piece, heavy-gauge aluminum with a rolled bead for extra strength directs exhaust air downward.	✓
Mounting Holes	Curb cap has prepunched mounting holes to ensure correct attachment to the roof.	✓
Internal Supports	Heavy-gauge supports and bracing are added for additional strength to withstand a wind of 150 mph (61 psf).	✓*
Roof Curb	High-wind load fans are certified with one of two Greenheck high-wind roof curbs. Standard 12-inch (305 mm) in height GPF curb has a 5-inch (127 mm) flashing flange. Roof curbs ship separate for field installation with attachment details provided.	✓*

* Applicable to fans with high wind option only.

Standard Construction Features Models G and GB

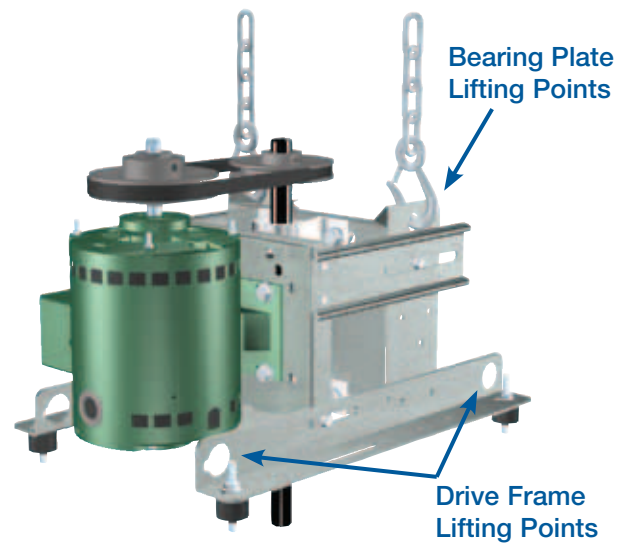
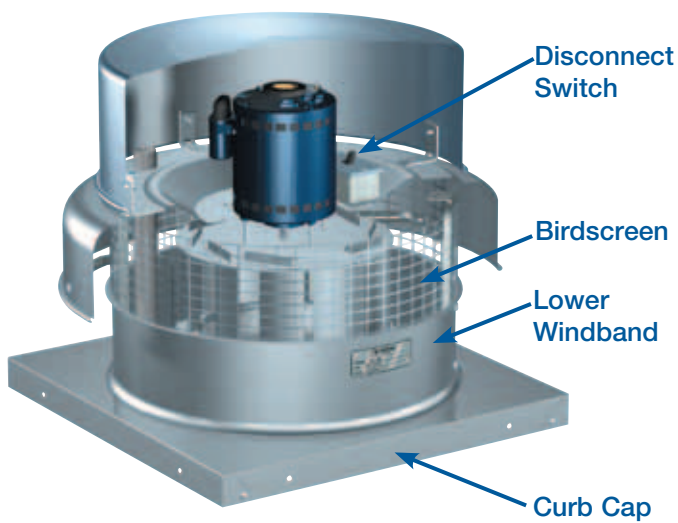
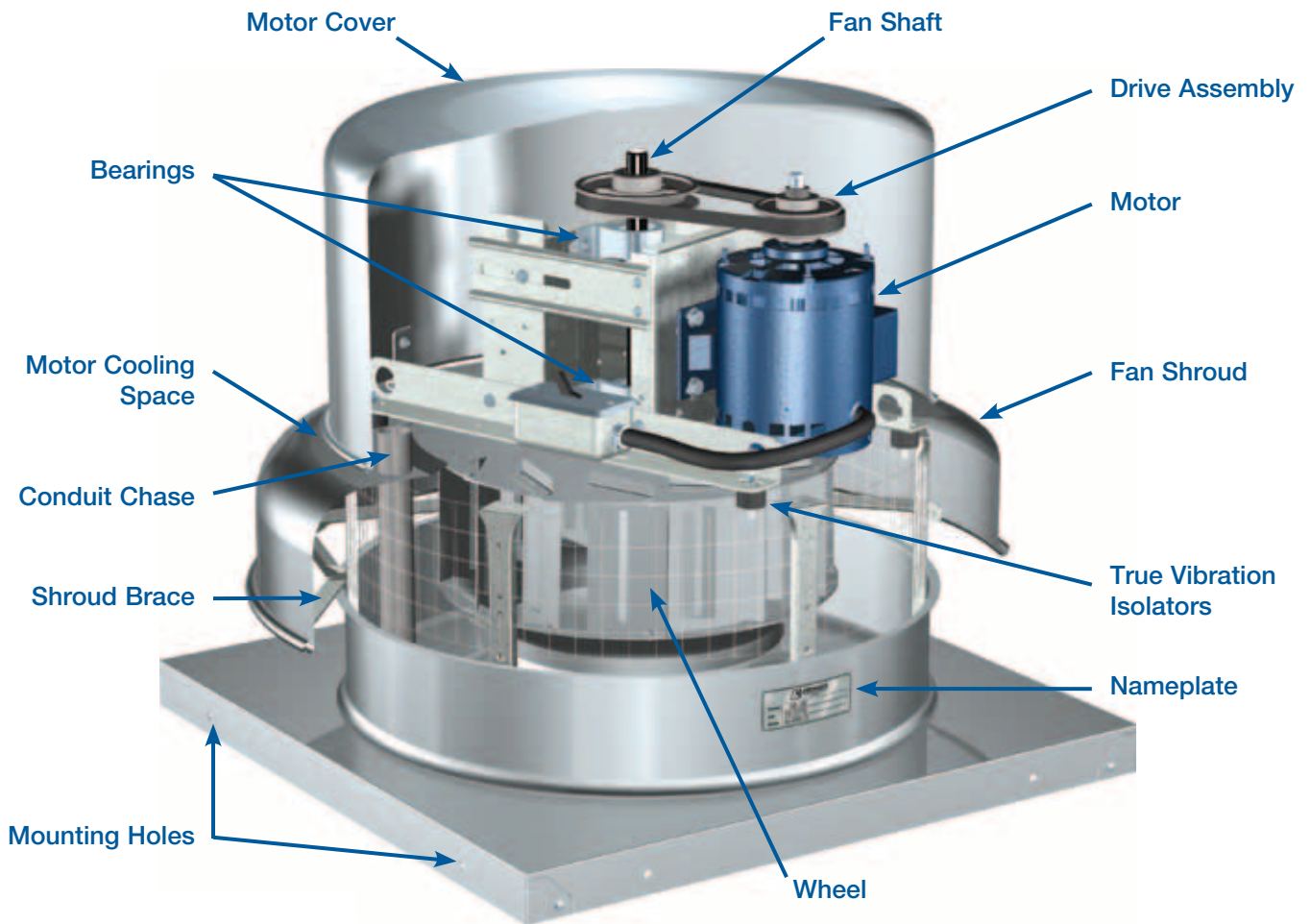

Roof Downblast - Belt Drive GB-071

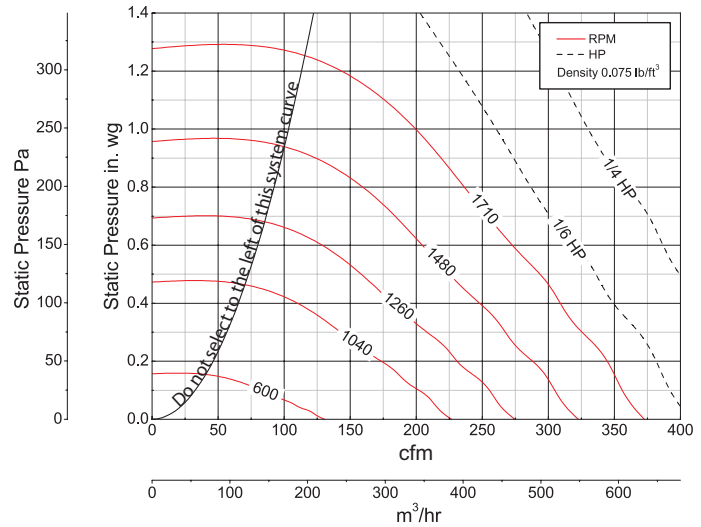
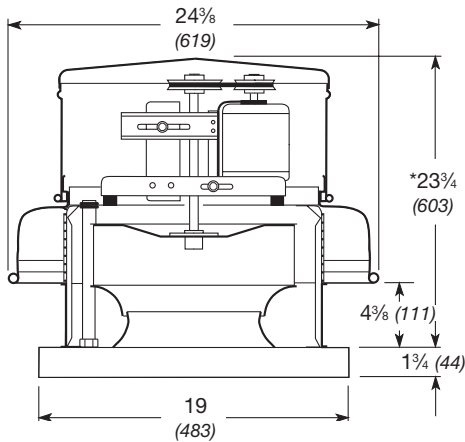

- Damper Size = 12 x 12 (305 x 305)
- Roof Opening = 14½ x 14½ (368 x 368)
- Shroud Thickness = 0.051 (1.3)
- Motor Cover Thickness = 0.040 (1.0)
- Curb Cap Thickness = 0.064 (1.6)
- ^Approximate Unit Weight = 58 lb (26 kg)

All dimensions in inches (millimeters). *May be greater depending on motor.
^Weight shown is largest cataloged Open Drip-Proof motor.

Model Number	Motor HP	Fan RPM	Static Pressure in Inches wg																			
			0	0.125	0.25	0.375	0.5	0.625	0.75	0.875	1	1.125										
071-6 or 071-4	1/6 or 1/4	630	CFM	137	79																	
			BHP	0.01	0.01																	
			Sones	1.3	1.4																	
		738	CFM	161	112																	
			BHP	0.01	0.01																	
			Sones	1.9	2.1																	
		846	CFM	184	144	95																
			BHP	0.02	0.02	0.01																
			Sones	2.7	2.6	2.6																
		954	CFM	208	172	132	76															
			BHP	0.02	0.02	0.02	0.02															
			Sones	3.5	3.6	3.4	3.2															
		1062	CFM	231	200	164	127															
			BHP	0.03	0.03	0.03	0.03															
			Sones	4.5	4.6	4.4	4.2															
		1170	CFM	255	227	196	162	123														
			BHP	0.04	0.04	0.04	0.04	0.04														
			Sones	5.7	5.7	5.5	5.2	5.0														
		1278	CFM	279	254	226	195	164	124													
			BHP	0.05	0.05	0.05	0.05	0.05	0.05													
Sones	6.7		6.7	6.5	6.2	6.0	5.8															
1386	CFM	302	280	253	226	197	169	129														
	BHP	0.07	0.07	0.07	0.07	0.07	0.07	0.06														
	Sones	7.6	7.6	7.4	7.2	6.9	6.7	6.5														
1494	CFM	326	305	280	257	230	203	177	138													
	BHP	0.09	0.09	0.09	0.09	0.09	0.09	0.08	0.07													
	Sones	8.6	8.6	8.4	8.2	7.9	7.6	7.5	7.3													
1602	CFM	349	329	308	286	262	237	212	186	150												
	BHP	0.11	0.11	0.11	0.11	0.11	0.10	0.10	0.10	0.09												
	Sones	9.8	9.7	9.6	9.3	9.1	8.8	8.5	8.4	8.1												
1710	CFM	373	353	335	312	292	269	246	223	198	164											
	BHP	0.13	0.13	0.13	0.13	0.13	0.13	0.13	0.12	0.12	0.11											
	Sones	11.1	11.0	11.0	10.6	10.3	10.0	9.8	9.5	9.3	9.1											

Performance certified is for installation type A: Free inlet, Free outlet. Power rating (BHP) does not include transmission losses. Performance ratings include the effects of a birdscreen. The sound ratings shown are loudness values in hemispherical sones at 5 ft. (1.5 m) in a hemispherical free field calculated per AMCA Standard 301. Values shown are for installation type A: free inlet hemispherical sone levels.

Roof Downblast - Belt Drive GB-081

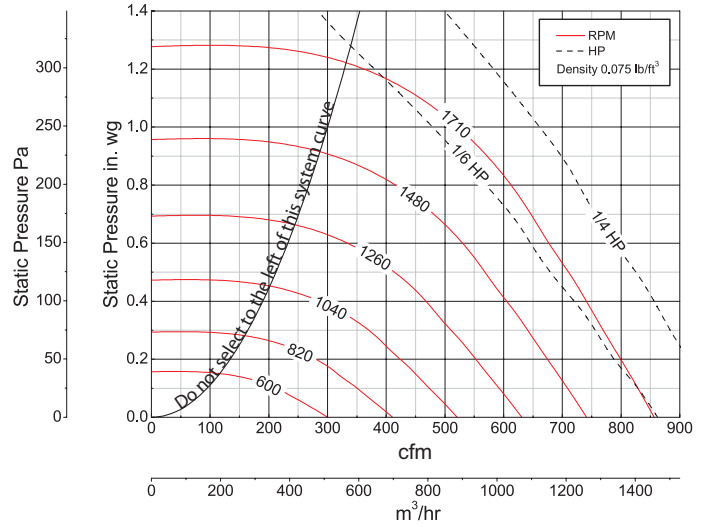
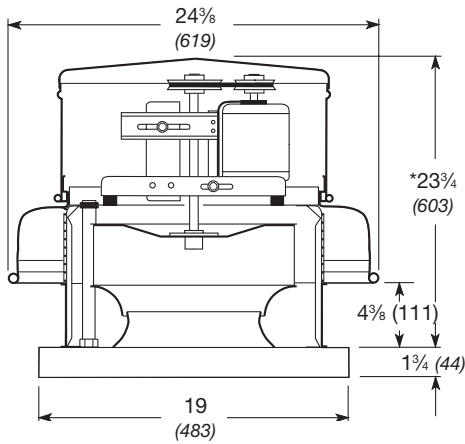

Damper Size = 12 x 12 (305 x 305)
 Roof Opening = $14\frac{1}{2}$ x $14\frac{1}{2}$ (368 x 368)
 Shroud Thickness = 0.051 (1.3)
 Motor Cover Thickness = 0.040 (1.0)
 Curb Cap Thickness = 0.064 (1.6)
 ^Approximate Unit Weight = 58 lb (26 kg)

All dimensions in inches (millimeters). *May be greater depending on motor.
 ^Weight shown is largest cataloged Open Drip-Proof motor.

Model Number	Motor HP	Fan RPM	Static Pressure in Inches wg																								
			0	0.125	0.25	0.375	0.5	0.625	0.75	0.875	1	1.125															
081-6 or 081-4	1/6 or 1/4	630	CFM	316	207																				MAXIMUM BHP AT A GIVEN RPM = $(RPM/2985)^3$ MAXIMUM RPM = 1710 TIP SPEED (ft/min) = RPM x 2.929 MAXIMUM MOTOR FRAME SIZE = 56		
			BHP	0.01	0.01																						
			Sones	2.4	2.1																						
		738	CFM	370	283																						
			BHP	0.01	0.02																						
			Sones	3.1	2.8																						
		864	CFM	433	361	265																					
			BHP	0.02	0.02	0.02																					
			Sones	4.0	3.8	3.5																					
		954	CFM	478	413	341																					
			BHP	0.03	0.03	0.03																					
			Sones	4.8	4.6	4.2																					
		1062	CFM	532	474	411	329																				
			BHP	0.04	0.04	0.05	0.04																				
			Sones	5.9	5.7	5.3	5.0																				
		1170	CFM	586	533	478	419	317																			
			BHP	0.05	0.06	0.06	0.06	0.06																			
			Sones	6.9	6.7	6.4	6.0	5.7																			
		1278	CFM	640	592	543	490	428	320																		
			BHP	0.07	0.07	0.08	0.08	0.08	0.07																		
			Sones	7.9	7.8	7.4	7.0	6.7	6.6																		
		1386	CFM	694	650	605	557	507	441	334																	
			BHP	0.09	0.09	0.10	0.10	0.10	0.10	0.09																	
			Sones	9.1	8.9	8.6	8.2	7.9	7.6	7.6																	
1494	CFM	748	708	666	623	577	528	457	357																		
	BHP	0.11	0.12	0.12	0.12	0.12	0.13	0.12	0.11																		
	Sones	10.1	10.0	9.8	9.4	8.9	8.7	8.5	8.4																		
1602	CFM	802	765	725	686	644	602	552	480	388																	
	BHP	0.14	0.14	0.15	0.15	0.15	0.15	0.16	0.15	0.14																	
	Sones	11.3	11.1	10.9	10.5	10.1	9.9	9.6	9.5	9.3																	
1710	CFM	856	821	785	748	710	669	630	581	511	424																
	BHP	0.17	0.17	0.18	0.18	0.19	0.19	0.19	0.19	0.18	0.17																
	Sones	12.5	12.3	12.1	11.9	11.5	11.2	10.9	10.6	10.5	10.3																

Performance certified is for installation type A: Free inlet, Free outlet. Power rating (BHP) does not include transmission losses. Performance ratings include the effects of a birdscreen. The sound ratings shown are loudness values in hemispherical sones at 5 ft. (1.5 m) in a hemispherical free field calculated per AMCA Standard 301. Values shown are for installation type A: free inlet hemispherical sone levels.

Roof Downblast - Belt Drive GB-091

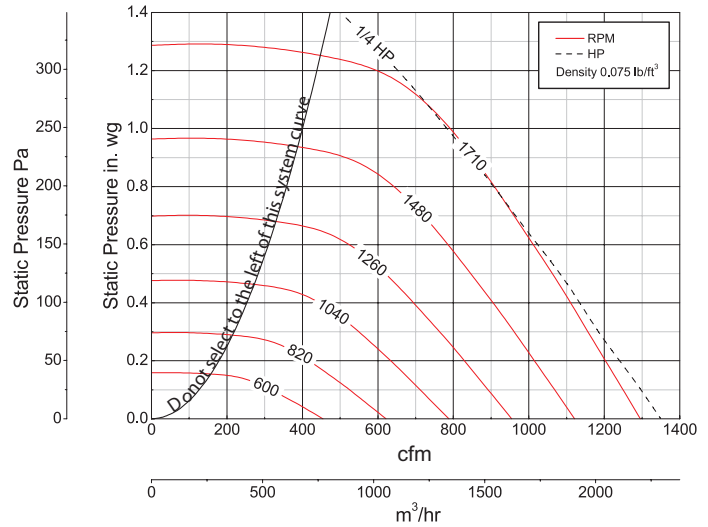
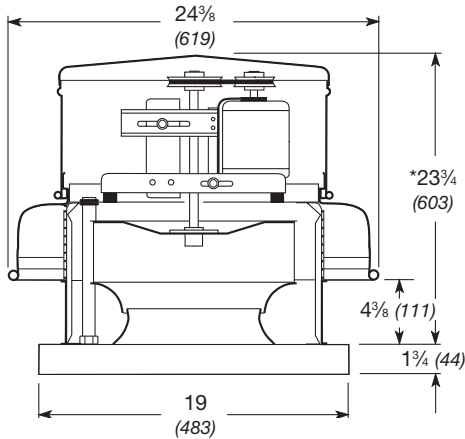

- Damper Size = 12 x 12 (305 x 305)
- Roof Opening = 14½ x 14½ (368 x 368)
- Shroud Thickness = 0.051 (1.3)
- Motor Cover Thickness = 0.040 (1.0)
- Curb Cap Thickness = 0.064 (1.6)
- ^Approximate Unit Weight = 58 lb (26 kg)

All dimensions in inches (millimeters). *May be greater depending on motor.
^Weight shown is largest cataloged Open Drip-Proof motor.

Model Number	Motor HP	Fan RPM	Static Pressure in Inches wg																				
			0	0.125	0.25	0.375	0.5	0.625	0.75	0.875	1	1.125											
091-4	1/4	630	CFM	477	309																		
			BHP	0.01	0.01																		
			Sones	2.9	3.0																		
		738	CFM	559	421																		
			BHP	0.02	0.02																		
			Sones	3.7	3.6																		
		864	CFM	655	539	405																	
			BHP	0.03	0.03	0.03																	
			Sones	4.9	4.8	4.5																	
		954	CFM	723	619	506	313																
			BHP	0.04	0.04	0.04	0.04																
			Sones	5.9	5.7	5.3	5.1																
		1062	CFM	805	711	613	502																
			BHP	0.05	0.06	0.06	0.06																
			Sones	7.2	7.0	6.6	6.2																
		1170	CFM	886	802	715	621	500															
			BHP	0.07	0.08	0.08	0.08	0.08															
			Sones	8.7	8.4	8.0	7.5	7.1															
		1278	CFM	968	891	813	729	639	516														
			BHP	0.09	0.10	0.10	0.10	0.11	0.10														
Sones	9.5		9.3	8.9	8.5	8.1	7.8																
1386	CFM	1050	979	907	832	752	666	545															
	BHP	0.12	0.12	0.13	0.13	0.13	0.14	0.13															
	Sones	10.3	10.1	9.9	9.5	9.1	8.8	8.5															
1494	CFM	1132	1066	999	932	860	785	698	584														
	BHP	0.15	0.15	0.16	0.16	0.17	0.17	0.17	0.16														
	Sones	11.2	11.1	10.9	10.6	10.2	9.9	9.6	9.3														
1602	CFM	1214	1152	1090	1028	962	894	823	738	631													
	BHP	0.18	0.19	0.19	0.20	0.20	0.20	0.21	0.21	0.20													
	Sones	12.3	12.1	12.0	11.8	11.4	11.1	10.8	10.5	10.2													
1710	CFM	1296	1238	1180	1122	1062	999	934	867	785	685												
	BHP	0.22	0.23	0.23	0.24	0.24	0.25	0.25	0.25	0.25	0.24												
	Sones	13.4	13.3	13.2	13.0	12.7	12.4	12.1	11.8	11.6	11.2												

MAXIMUM BHP AT A GIVEN RPM = (RPM/2703)³
 MAXIMUM RPM = 1710
 TIP SPEED (ft/min) = RPM x 2.929
 MAXIMUM MOTOR FRAME SIZE = 56

Performance certified is for installation type A: Free inlet, Free outlet. Power rating (BHP) does not include transmission losses. Performance ratings include the effects of a birdscreen. The sound ratings shown are loudness values in hemispherical sones at 5 ft. (1.5 m) in a hemispherical free field calculated per AMCA Standard 301. Values shown are for installation type A: free inlet hemispherical sone levels.

Roof Downblast - Belt Drive GB-101HP

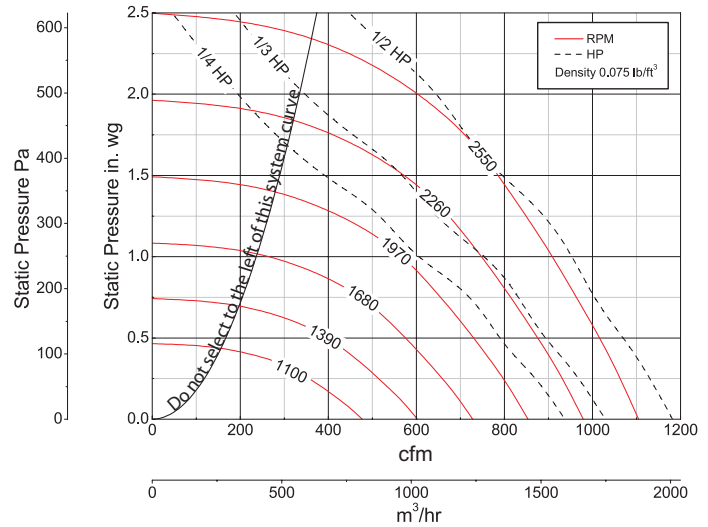
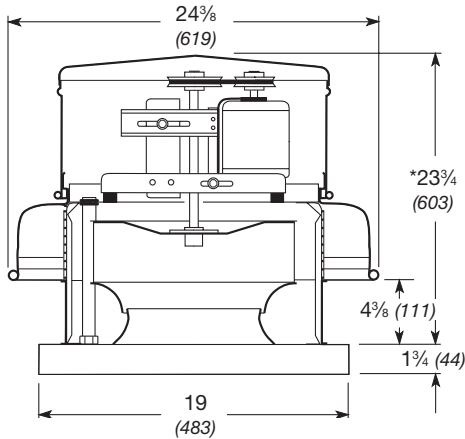

Damper Size = 12 x 12 (305 x 305)
 Roof Opening = $14\frac{1}{2}$ x $14\frac{1}{2}$ (368 x 368)
 Shroud Thickness = 0.051 (1.3)
 Motor Cover Thickness = 0.040 (1.0)
 Curb Cap Thickness = 0.064 (1.6)
 ^Approximate Unit Weight = 63 lb (29 kg)

All dimensions in inches (millimeters). *May be greater depending on motor.
 ^Weight shown is largest cataloged Open Drip-Proof motor.

Model Number	Motor HP	Fan RPM	Static Pressure in Inches wg																				
			0	0.25	0.5	0.75	1	1.25	1.5	1.75	2	2.25											
101HP-4	1/4	1300	CFM	571	477	342																	
			BHP	0.06	0.06	0.07																	
			Sones	6.6	5.7	5.3																	
		1445	CFM	635	553	449	243																
			BHP	0.08	0.09	0.09	0.08																
			Sones	8.4	7.5	7.0	6.3																
	1590	CFM	699	626	537	417																	
		BHP	0.10	0.11	0.12	0.12																	
		Sones	10.4	9.5	9.1	8.3																	
	1735	CFM	762	697	619	527	376																
		BHP	0.13	0.15	0.15	0.16	0.15																
		Sones	11.5	10.8	10.7	10.3	10.2																
1880	CFM	826	767	697	618	518	337																
	BHP	0.17	0.18	0.20	0.20	0.21	0.18																
	Sones	12.7	12.2	11.9	12	11.4	11.9																
2025	CFM	890	836	772	702	622	515	313															
	BHP	0.21	0.23	0.24	0.24	0.26	0.25	0.22															
	Sones	14.2	13.6	13.3	13.2	12.6	12	11.4															
101HP-3	1/3	2137	CFM	939	889	830	765	693	607	474													
			BHP	0.25	0.26	0.28	0.28	0.30	0.30	0.28													
		Sones	15.4	14.8	14.4	14.2	13.4	13.1	12.1														
	2229	CFM	979	931	875	814	748	674	574	406													
		BHP	0.29	0.30	0.31	0.32	0.33	0.35	0.33	0.31													
		Sones	15.8	15.4	14.8	14.5	14.1	13.7	13.2														
101HP-5	1/2	2336	CFM	1026	981	928	871	809	742	661	543	358											
			BHP	0.33	0.34	0.36	0.37	0.37	0.39	0.40	0.38	0.34											
		Sones	16.4	16.0	15.4	14.9	14.7	14.0	14.1	13.5	13.6												
	2443	CFM	1073	1030	981	927	869	807	739	649	519												
		BHP	0.38	0.39	0.41	0.42	0.42	0.44	0.46	0.44	0.42												
		Sones	17.3	16.9	16.4	16.0	14.9	14.5	14.7	15.0													
2550	CFM	1120	1078	1032	982	928	869	807	735	639	497												
	BHP	0.43	0.44	0.46	0.48	0.48	0.49	0.51	0.52	0.50	0.47												
	Sones	18.2	17.9	17.4	17.2	16.3	16.1	15.1	15.6	16.2	17.2												

Performance certified is for installation type A: Free inlet, Free outlet. Power rating (BHP) does not include transmission losses. Performance ratings include the effects of a birdscreen. The sound ratings shown are loudness values in hemispherical sones at 5 ft. (1.5 m) in a hemispherical free field calculated per AMCA Standard 301. Values shown are for installation type A: free inlet hemispherical sone levels.

Roof Downblast - Belt Drive GB-121

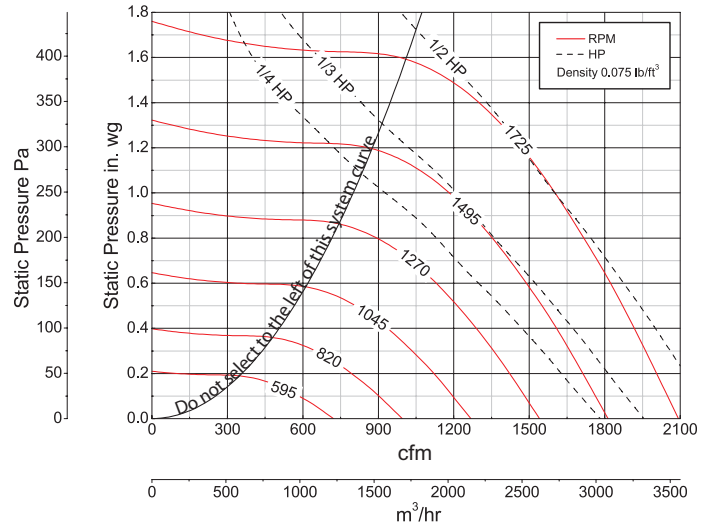
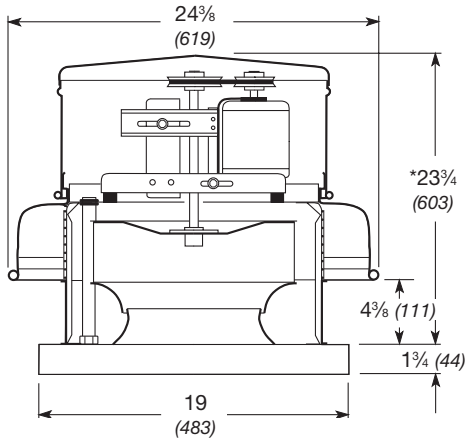

- Damper Size = 12 x 12 (305 x 305)
- Roof Opening = 14½ x 25½ (368 x 368)
- Shroud Thickness = 0.051 (1.3)
- Motor Cover Thickness = 0.040 (1.0)
- Curb Cap Thickness = 0.064 (1.6)
- ^Approximate Unit Weight = 66 lb (30 kg)

All dimensions in inches (millimeters). *May be greater depending on motor.
^Weight shown is largest cataloged Open Drip-Proof motor.

Model Number	Motor HP	Fan RPM	Static Pressure in Inches wg																			
			0	0.125	0.25	0.375	0.5	0.625	0.75	1	1.25	1.5										
121-4	1/4	595	CFM	722	542																	
			BHP	0.02	0.02																	
			Sones	3.3	3.4																	
		728	CFM	883	747	543																
			BHP	0.03	0.04	0.04																
			Sones	4.2	4.3	4.2																
		861	CFM	1044	933	798	584															
			BHP	0.05	0.06	0.06	0.06															
			Sones	5.4	5.5	5.2	5.2															
		994	CFM	1206	1111	1004	872	673														
			BHP	0.08	0.09	0.09	0.10	0.09														
			Sones	6.7	6.7	6.6	6.4	6.3														
1127	CFM	1367	1284	1195	1092	969	799															
	BHP	0.11	0.12	0.13	0.14	0.14	0.13															
	Sones	8.2	8.2	8.2	7.9	7.8	7.7															
1260	CFM	1528	1454	1377	1292	1196	1084	938														
	BHP	0.16	0.17	0.18	0.19	0.19	0.19	0.19														
	Sones	10.1	10.1	10.0	9.9	9.6	9.5	9.3														
1395	CFM	1692	1625	1557	1484	1404	1315	1214	907													
	BHP	0.21	0.23	0.24	0.25	0.26	0.26	0.26	0.25													
	Sones	12.5	12.4	12.3	12.2	12.0	11.7	11.5	11.3													
121-3	1/3	1473	CFM	1787	1723	1659	1591	1518	1438	1352	1127											
			BHP	0.25	0.27	0.28	0.29	0.30	0.31	0.31	0.30											
			Sones	13.5	13.4	13.3	13.1	12.9	12.7	12.4	12.0											
		1550	CFM	1880	1820	1759	1696	1629	1555	1475	1289	974										
			BHP	0.30	0.31	0.32	0.33	0.34	0.35	0.36	0.36	0.33										
			Sones	14.6	14.5	14.3	14.2	14.0	13.8	13.5	12.9	12.4										
121-5	1/2	1638	CFM	1987	1930	1872	1814	1751	1684	1613	1452	1238										
			BHP	0.35	0.36	0.38	0.39	0.40	0.41	0.42	0.43	0.42										
			Sones	16.0	15.8	15.6	15.5	15.3	15.1	14.9	14.0	13.5										
		1725	CFM	2093	2038	1984	1928	1871	1810	1743	1600	1426	1180									
			BHP	0.40	0.42	0.44	0.45	0.46	0.47	0.48	0.50	0.50	0.48									
			Sones	17.4	17.2	17.0	16.8	16.7	16.4	16.2	15.5	14.9	14.0									

Performance certified is for installation type A: Free inlet, Free outlet. Power rating (BHP) does not include transmission losses. Performance ratings include the effects of a birdscreen. The sound ratings shown are loudness values in hemispherical sones at 5 ft. (1.5 m) in a hemispherical free field calculated per AMCA Standard 301. Values shown are for installation type A: free inlet hemispherical sone levels.

Roof Downblast - Belt Drive GB-131

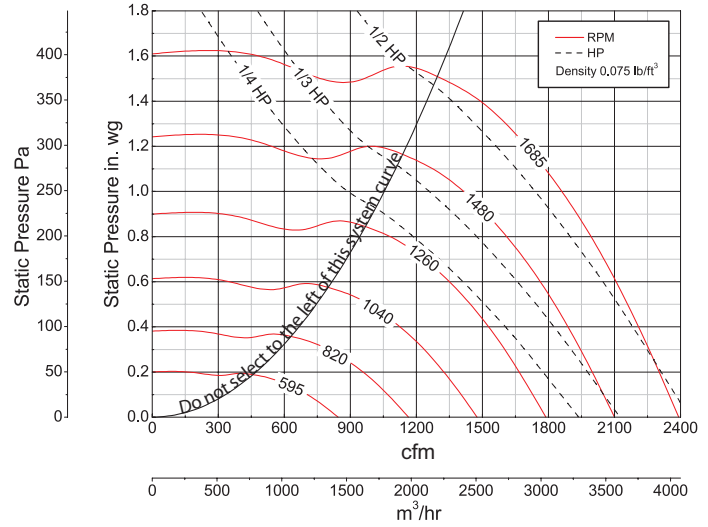
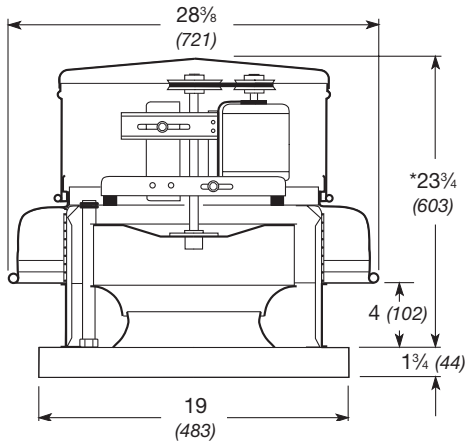

- Damper Size = 12 x 12 (305 x 305)
- Roof Opening = 14½ x 14½ (368 x 368)
- Shroud Thickness = 0.051 (1.3)
- Motor Cover Thickness = 0.040 (1.0)
- Curb Cap Thickness = 0.064 (1.6)
- ^Approximate Unit Weight = 67 lb (30 kg)

All dimensions in inches (millimeters). *May be greater depending on motor.
^Weight shown is largest cataloged Open Drip-Proof motor.

Model Number	Motor HP	Fan RPM		Static Pressure in Inches wg																
				0	0.125	0.25	0.375	0.5	0.625	0.75	1	1.25	1.5							
131-4	1/4	595	CFM	844	655														MAXIMUM BHP AT A GIVEN RPM = (RPM/2047) ³ MAXIMUM RPM = 1685 TIP SPEED (ft/min) = RPM x 3.436 MAXIMUM MOTOR FRAME SIZE = 56	
			BHP	0.02	0.02															
			Sones	4.5	4.6															
		700	CFM	993	845	585														
			BHP	0.03	0.04	0.04														
			Sones	5.2	5.2	5.0														
		800	CFM	1135	1012	843														
			BHP	0.05	0.06	0.06														
			Sones	6.0	6.0	5.7														
		900	CFM	1277	1169	1039	845													
			BHP	0.07	0.08	0.08	0.08													
			Sones	7.0	6.9	6.6	6.3													
		1000	CFM	1419	1223	1213	1075	867												
			BHP	0.10	0.11	0.11	0.12	0.11												
			Sones	8.1	8.0	7.7	7.4	7.0												
		1100	CFM	1516	1475	1381	1268	1124	898											
			BHP	0.13	0.14	0.15	0.15	0.16	0.15											
			Sones	9.5	9.2	9.0	8.6	8.3	7.9											
1200	CFM	1703	1624	1539	1443	1330	1191	964												
	BHP	0.17	0.18	0.19	0.20	0.20	0.20	0.19												
	Sones	11.1	10.8	10.5	10.1	9.7	9.4	8.8												
1315	CFM	1866	1794	1718	1637	1545	1435	1305												
	BHP	0.22	0.23	0.24	0.25	0.26	0.26	0.26												
	Sones	13.2	12.8	12.5	12.1	11.7	11.2	10.9												
131-3	1/3	1440	CFM	2044	1978	1911	1838	1759	1674	1571	1299									
			BHP	0.294	0.306	0.318	0.327	0.336	0.344	0.347	0.342									
			Sones	15.0	15.0	15.1	15.1	14.5	13.9	13.4	12.5									
131-5	1/2	1563	CFM	2218	2158	2097	2031	1964	1887	1807	1606	1300								
			BHP	0.375	0.389	0.402	0.413	0.424	0.432	0.44	0.445	0.427								
			Sones	16.0	15.8	15.6	15.5	15.2	14.8	14.3	13.6	12.8								
		1685	CFM	2391	2335	2279	2219	2158	2093	2020	1857	1654	1312							
			BHP	0.47	0.485	0.499	0.512	0.523	0.534	0.543	0.555	0.557	0.522							
			Sones	16.9	16.6	16.3	16.0	15.7	15.4	15.1	14.5	13.9	13.5							

Performance certified is for installation type A: Free inlet, Free outlet. Power rating (BHP) does not include transmission losses. Performance ratings include the effects of a birdscreen. The sound ratings shown are loudness values in hemispherical sones at 5 ft. (1.5 m) in a hemispherical free field calculated per AMCA Standard 301. Values shown are for installation type A: free inlet hemispherical sone levels.

Roof Downblast - Belt Drive GB-141

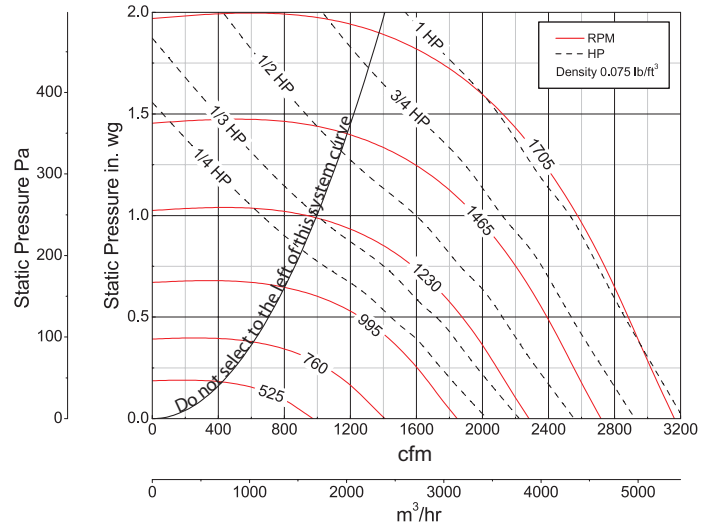
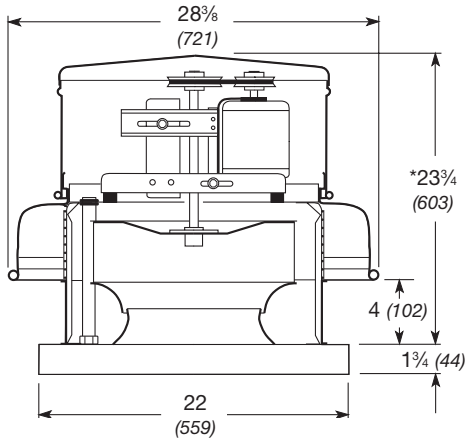

Damper Size = 16 x 16 (406 x 406)
 Roof Opening = 18 1/2 x 18 1/2 (470 x 470)
 Shroud Thickness = 0.051 (1.3)
 Motor Cover Thickness = 0.040 (1.0)
 Curb Cap Thickness = 0.064 (1.6)
 ^Approximate Unit Weight = 83 lb (38 kg)

All dimensions in inches (millimeters). *May be greater depending on motor.
 ^Weight shown is largest cataloged Open Drip-Proof motor.

Model Number	Motor HP	Fan RPM		Static Pressure in Inches wg																	
				0	0.125	0.25	0.375	0.5	0.75	1	1.25	1.5	1.75								
141-4	1/4	525	CFM	974	709																
			BHP	0.03	0.03																
			Sones	4.4	4.2																
		663	CFM	1230	1046	732															
			BHP	0.06	0.06	0.06															
			Sones	5.3	5.5	4.4															
	801	CFM	1486	1337	1161	850															
		BHP	0.10	0.11	0.11	0.10															
		Sones	6.5	6.6	6.1	5.3															
	939	CFM	1742	1614	1482	1313	1040														
		BHP	0.16	0.17	0.17	0.18	0.16														
		Sones	7.9	7.8	7.5	7.0	6.4														
1075	CFM	1994	1882	1771	1647	1490															
	BHP	0.24	0.25	0.26	0.26	0.26															
	Sones	10.0	9.9	9.4	8.9	8.4															
141-3	1/3	1170	CFM	2170	2067	1966	1859	1734	1356												
			BHP	0.31	0.32	0.33	0.33	0.34	0.32												
			Sones	11.4	11.3	10.8	10.3	9.9	8.7												
141-5	1/2	1265	CFM	2347	2250	2158	2062	1955	1677	1048											
			BHP	0.39	0.40	0.41	0.42	0.42	0.42	0.35											
			Sones	12.9	12.7	12.3	11.9	11.4	10.4	8.8											
		1360	CFM	2523	2433	2347	2259	2166	1943	1602											
			BHP	0.48	0.50	0.51	0.52	0.52	0.53	0.51											
			Sones	14.6	14.3	13.9	13.5	13.1	12.2	11.0											
141-7	3/4	1453	CFM	2695	2612	2530	2449	2365	2173	1914	1513										
			BHP	0.59	0.60	0.62	0.63	0.64	0.64	0.60											
			Sones	16.2	15.9	15.6	15.3	14.8	13.9	13.0	11.8										
		1545	CFM	2866	2787	2710	2634	2556	2384	2177	1890										
			BHP	0.71	0.72	0.74	0.75	0.76	0.77	0.78	0.75										
			Sones	17.6	18.0	17.4	17.1	16.8	14.9	14.7	14.7										
141-10	1	1705	CFM	3163	3091	3020	2952	2883	2739	2574	2370	2120	1731								
			BHP	0.95	0.97	0.98	1.00	1.02	1.03	1.03	1.05	1.02	0.96								
			Sones	20	20	20	19.6	19.2	18.1	16.9	16.7	16.6	16.4								

Performance certified is for installation type A: Free inlet, Free outlet. Power rating (BHP) does not include transmission losses. Performance ratings include the effects of a birdscreen. The sound ratings shown are loudness values in hemispherical sones at 5 ft. (1.5 m) in a hemispherical free field calculated per AMCA Standard 301. Values shown are for installation type A: free inlet hemispherical sone levels.

Roof Downblast - Belt Drive GB-161

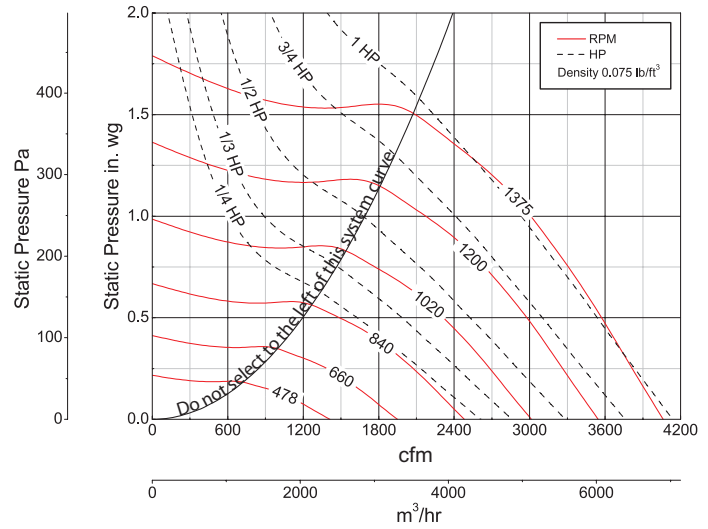
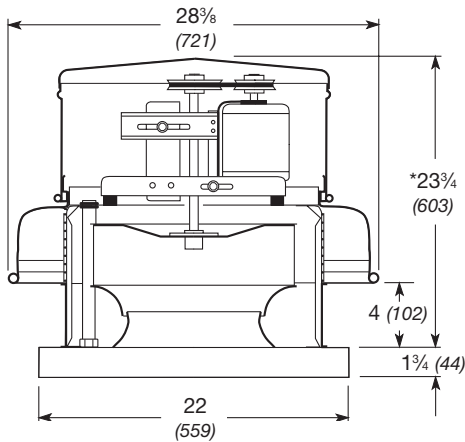

Damper Size = 16 x 16 (406 x 406)
 Roof Opening = 18 1/2 x 18 1/2 (470 x 470)
 Shroud Thickness = 0.051 (1.3)
 Motor Cover Thickness = 0.040 (1.0)
 Curb Cap Thickness = 0.064 (1.6)
 ^Approximate Unit Weight = 89 lb (40 kg)

All dimensions in inches (millimeters). *May be greater depending on motor.
 ^Weight shown is largest cataloged Open Drip-Proof motor.

Model Number	Motor HP	Fan RPM	Static Pressure in Inches wg																			
			0	0.125	0.25	0.375	0.5	0.75	0.875	1	1.25	1.5										
161-4	1/4	478	CFM	1412	1030																	
			BHP	0.40	0.04																	
			Sones	4.7	4.5																	
		575	CFM	1698	1399	937																
			BHP	0.07	0.08	0.07																
			Sones	5.7	5.6	5.3																
	670	CFM	1979	1727	1429																	
		BHP	0.11	0.12	0.12																	
		Sones	7.0	6.7	6.5																	
	765	CFM	2260	2040	1802	1494																
		BHP	0.16	0.17	0.18	0.18																
		Sones	8.6	8.2	8.0	7.5																
865	CFM	2555	2360	2162	1933	1624																
	BHP	0.24	0.25	0.26	0.26	0.25																
	Sones	10.6	10.1	9.7	9.4	8.8																
161-3	1/3	945	CFM	2791	2612	2434	2236	2010														
			BHP	0.31	0.32	0.33	0.34	0.34														
			Sones	12.6	12.0	11.5	11.2	10.7														
161-5	1/2	1023	CFM	3022	2856	2693	2520	2327	1785													
			BHP	0.39	0.41	0.42	0.43	0.43	0.40													
			Sones	14.0	13.4	12.8	12.5	12.1	11.0													
		1100	CFM	3249	3095	2943	2787	2615	2198	1900												
			BHP	0.49	0.50	0.52	0.53	0.53	0.52	0.50												
			Sones	15.3	14.7	14.1	13.8	13.5	12.5	12.0												
161-7	3/4	1175	CFM	3471	3326	3184	3040	2888	2541	2313	2025											
			BHP	0.59	0.61	0.62	0.64	0.65	0.65	0.64	0.61											
			Sones	16.5	16.0	15.5	15.1	14.8	14.0	13.6	13.0											
		1250	CFM	3692	3557	3422	3289	3149	2838	2658	2444											
			BHP	0.71	0.73	0.75	0.76	0.77	0.79	0.78	0.76											
			Sones	17.9	17.4	17.0	16.6	16.3	15.6	15.2	14.9											
161-10	1	1375	CFM	4062	3938	3815	3694	3571	3304	3161	3007	2609	2073									
			BHP	0.95	0.97	0.99	1.01	1.02	1.04	1.05	1.04	1.01	0.93									
			Sones	21	20	19.6	19.2	18.9	18.4	18.0	17.6	17.2	15.4									

Performance certified is for installation type A: Free inlet, Free outlet. Power rating (BHP) does not include transmission losses. Performance ratings include the effects of a birdscreen. The sound ratings shown are loudness values in hemispherical sones at 5 ft. (1.5 m) in a hemispherical free field calculated per AMCA Standard 301. Values shown are for installation type A: free inlet hemispherical sone levels.

Roof Downblast - Belt Drive GB-161HP

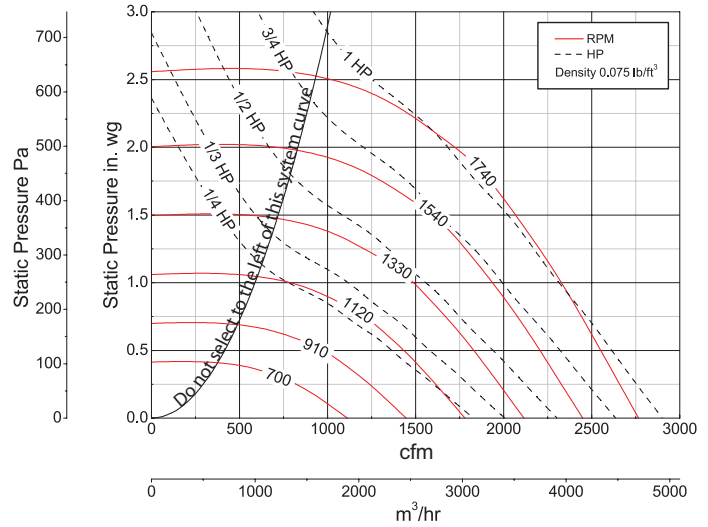
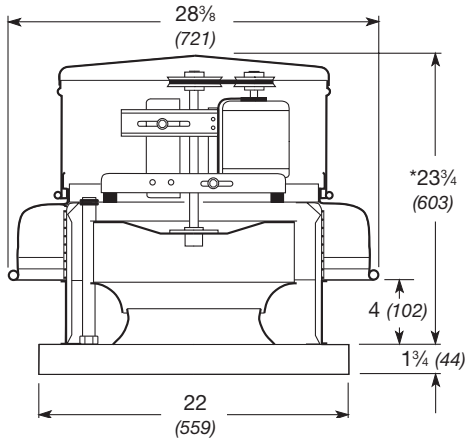

Damper Size = 16 x 16 (406 x 406)
 Roof Opening = 18 1/2 x 18 1/2 (470 x 470)
 Shroud Thickness = 0.051 (1.3)
 Motor Cover Thickness = 0.040 (1.0)
 Curb Cap Thickness = 0.064 (1.6)
 ^Approximate Unit Weight = 89 lb (40 kg)

All dimensions in inches (millimeters). *May be greater depending on motor.
 ^Weight shown is largest cataloged Open Drip-Proof motor.

Model Number	Motor HP	Fan RPM	Static Pressure in Inches wg																			
			0.5	0.625	0.75	1	1.25	1.5	1.75	2	2.25	2.5										
161HP-4	1/4	825	CFM	702																		
			BHP	0.11																		
			Sones	6.5																		
		960	CFM	1093	919	585																
			BHP	0.18	0.17	0.15																
			Sones	7.7	7.6	8.0																
1095	CFM	1380	1271	1139	589																	
	BHP	0.26	0.26	0.26	0.21																	
	Sones	9.0	9.0	8.9	9.5																	
161HP-3	1/3	1210	CFM	1606	1514	1416	1149															
			BHP	0.34	0.35	0.35	0.34															
			Sones	10.6	10.3	10.4	10.3															
161HP-5	1/2	1270	CFM	1718	1636	1545	1333	949														
			BHP	0.39	0.40	0.40	0.41	0.37														
			Sones	11.4	11.2	11.1	11.1	11.4														
		1330	CFM	1829	1753	1668	1483	1204														
			BHP	0.44	0.45	0.46	0.47	0.45														
			Sones	12.3	12.1	11.9	12.1	12.0														
1390	CFM	1938	1865	1789	1619	1399	1032															
	BHP	0.50	0.51	0.52	0.53	0.48																
	Sones	13.3	13.0	12.8	12.7	13.1																
161HP-7	3/4	1485	CFM	2109	2041	1973	1822	1654	1416	1012												
			BHP	0.60	0.61	0.63	0.64	0.65	0.63	0.57												
			Sones	14.9	14.7	14.4	13.8	13.7	14.0	14.7												
		1580	CFM	2275	2214	2150	2016	1868	1704	1447	1034											
			BHP	0.72	0.73	0.75	0.77	0.77	0.791	0.75	0.67											
			Sones	16.7	16.7	16.4	15.5	14.7	14.8	15.4	16.6											
161HP-10	1	1660	CFM	2414	2357	2297	2175	2037	1887	1702	1441	996										
			BHP	0.82	0.84	0.85	0.89	0.89	0.91	0.90	0.86	0.75										
			Sones	18.3	18.8	18.3	16.7	16.2	15.8	15.8	17.1	20										
		1740	CFM	2551	2497	2442	2325	2200	2066	1917	1714	1452	987									
			BHP	0.94	0.96	0.97	1.01	1.03	1.03	1.05	1.03	0.98	0.85									
			Sones	20	21	21	18.4	17.5	17.2	16.8	17.2	19.2	28									

Performance certified is for installation type A: Free inlet, Free outlet. Power rating (BHP) does not include transmission losses. Performance ratings include the effects of a birdscreen. The sound ratings shown are loudness values in hemispherical sones at 5 ft. (1.5 m) in a hemispherical free field calculated per AMCA Standard 301. Values shown are for installation type A: free inlet hemispherical sone levels.

Roof Downblast - Belt Drive GB-180

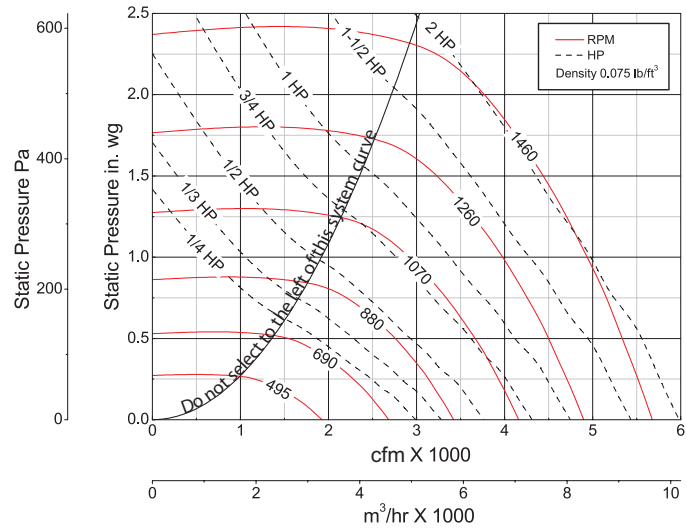
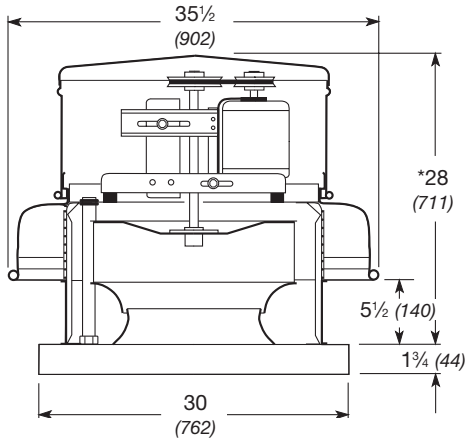

Damper Size = 18 x 18 (457 x 457)
 Roof Opening = 20½ x 20½ (521 x 521)
 Shroud Thickness = 0.064 (1.6)
 Motor Cover Thickness = 0.040 (1.0)
 Curb Cap Thickness = 0.064 (1.6)
 ^Approximate Unit Weight = 125 lb (57 kg)

All dimensions in inches (millimeters). *May be greater depending on motor.
 ^Weight shown is largest cataloged Open Drip-Proof motor.

Model Number	Motor HP	Fan RPM		Static Pressure in Inches wg												
				0	0.125	0.25	0.5	0.75	1	1.25	1.5	1.75	2			
180-4	1/4	495	CFM	1925	1646	1150										
			BHP	0.07	0.08	0.08										
			Sones	4.3	4.7	4.1										
		730	CFM	2839	2668	2469	1882									
			BHP	0.21	0.23	0.27	0.25									
			Sones	7.4	8.7	7.2	6.7									
180-3	1/3	810	CFM	3150	2997	2832	2375									
			BHP	0.29	0.31	0.33	0.35									
			Sones	8.8	9.9	8.7	8.2									
180-5	1/2	875	CFM	3402	3263	3113	2728	2144								
			BHP	0.37	0.38	0.41	0.44	0.43								
			Sones	10.5	11.1	10.2	9.4	8.5								
		940	CFM	3655	3527	3388	3052	2601								
			BHP	0.46	0.47	0.49	0.54	0.54								
			Sones	12.7	12.8	12.0	11.1	10.3								
180-7	3/4	1055	CFM	4102	3990	3867	3596	3252	2811							
			BHP	0.65	0.67	0.68	0.74	0.77	0.77							
			Sones	16.2	15.7	14.9	14.0	12.9	12.4							
180-10	1	1120	CFM	4355	4249	4134	3891	3587	3217	2686						
			BHP	0.77	0.79	0.81	0.88	0.92	0.93	0.89						
			Sones	17.5	16.9	16.4	15.5	14.5	13.8	13.0						
		1185	CFM	4608	4508	4401	4179	3900	3575	3178	2499					
			BHP	0.91	0.94	0.96	1.03	1.07	1.10	1.09	0.99					
			Sones	19.0	18.4	17.8	17.1	16.2	15.4	14.7	13.7					
180-15	1½	1260	CFM	4899	4805	4706	4498	4256	3977	3641	3223					
			BHP	1.10	1.12	1.15	1.21	1.27	1.32	1.32	1.29					
			Sones	21	19.9	19.3	18.8	18.0	17.3	16.8	16.1					
		1335	CFM	5191	5102	5010	4814	4599	4344	4052	3713	3262				
			BHP	1.31	1.33	1.36	1.41	1.49	1.54	1.57	1.56	1.51				
			Sones	22	22	21	21	19.9	19.2	18.7	18.2	17.6				
180-20	2	1460	CFM	5677	5596	5514	5336	5155	4938	4699	4426	4123	3765			
			BHP	1.71	1.74	1.77	1.81	1.93	1.97	2.03	2.05	2.05	2.02			
			Sones	26	25	24	24	23	23	22	22	22	21			

Performance certified is for installation type A: Free inlet, Free outlet. Power rating (BHP) does not include transmission losses. Performance ratings include the effects of a birdscreen. The sound ratings shown are loudness values in hemispherical sones at 5 ft. (1.5 m) in a hemispherical free field calculated per AMCA Standard 301. Values shown are for installation type A: free inlet hemispherical sone levels.

Roof Downblast - Belt Drive GB-180HP

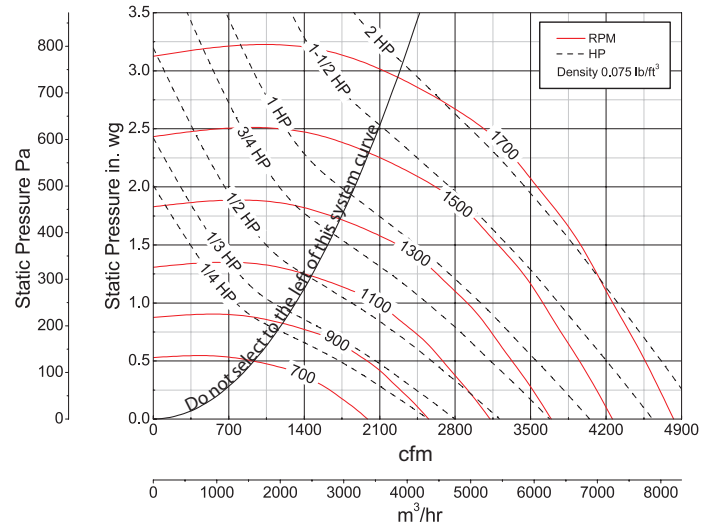
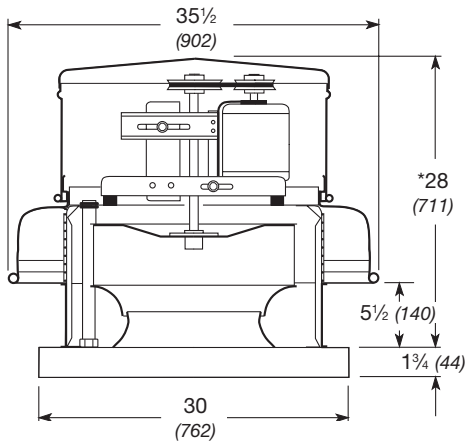

Damper Size = 18 x 18 (457 x 457)
 Roof Opening = 20½ x 20½ (521 x 521)
 Shroud Thickness = 0.064 (1.6)
 Motor Cover Thickness = 0.040 (1.0)
 Curb Cap Thickness = 0.064 (1.6)
 ^Approximate Unit Weight = 125 lb (57 kg)

All dimensions in inches (millimeters). *May be greater depending on motor.
 ^Weight shown is largest cataloged Open Drip-Proof motor.

Model Number	Motor HP	Fan RPM		Static Pressure in Inches wg																		
				0.5	0.75	1	1.25	1.5	1.75	2	2.25	2.5	2.75									
180HP-4	1/4	795	CFM	1547																		
			BHP	0.22																		
			Sones	8.6																		
		845	CFM	1759																		
			BHP	0.26																		
			Sones	9.1																		
180HP-3	1/3	935	CFM	2114	1686																	
			BHP	0.35	0.35																	
			Sones	10.3	9.6																	
180HP-5	1/2	1075	CFM	2601	2316	1920																
			BHP	0.51	0.53	0.52																
			Sones	12.9	12.1	11.6																
180HP-7	3/4	1150	CFM	2847	2607	2298	1811															
			BHP	0.61	0.64	0.65	0.62															
			Sones	14.6	13.1	12.6	12.3															
		1225	CFM	3088	2880	2610	2277	1711														
			BHP	0.73	0.77	0.78	0.78	0.72														
			Sones	16.3	14.7	13.9	13.3	13.2														
180HP-10	1	1350	CFM	3485	3296	3095	2840	2540	2059													
			BHP	0.96	1.00	1.04	1.05	1.05	0.99													
			Sones	19.5	17.6	16.4	15.8	15.0	15.1													
180HP-15	1½	1445	CFM	3782	3604	3428	3213	2969	2670	2216												
			BHP	1.16	1.21	1.25	1.28	1.29	1.28	1.21												
			Sones	22	20	18.8	17.8	17.3	16.4	16.6												
		1540	CFM	4076	3909	3744	3576	3353	3119	2827	2407											
			BHP	1.39	1.44	1.49	1.53	1.55	1.56	1.55	1.48											
			Sones	25	22	21	20	19.6	18.9	18.1	18.3											
180HP-20	2	1620	CFM	4319	4163	4005	3848	3663	3450	3223	2923	2512										
			BHP	1.60	1.66	1.71	1.76	1.79	1.81	1.82	1.80	1.72										
			Sones	27	25	24	23	22	21	20	19.7	19.8										
		1700	CFM	4560	4414	4263	4114	3964	3764	3560	3340	3037	2642									
			BHP	1.84	1.90	1.96	2.01	2.06	2.08	2.10	2.11	2.07	1.99									
			Sones	30	27	26	25	24	23	22	22	21	21									

Performance certified is for installation type A: Free inlet, Free outlet. Power rating (BHP) does not include transmission losses. Performance ratings include the effects of a birdscreen. The sound ratings shown are loudness values in hemispherical sones at 5 ft. (1.5 m) in a hemispherical free field calculated per AMCA Standard 301. Values shown are for installation type A: free inlet hemispherical sone levels.

Roof Downblast - Belt Drive GB-200

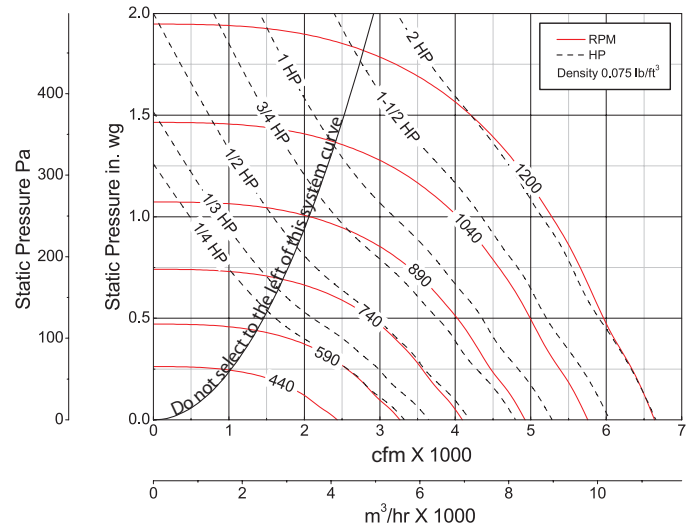
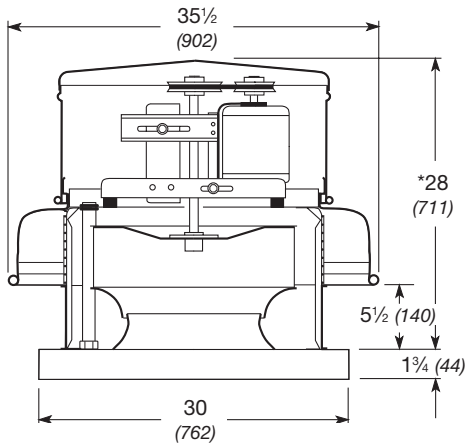

Damper Size = 18 x 18 (457 x 457)
 Roof Opening = 20½ x 20½ (521 x 521)
 Shroud Thickness = 0.064 (1.6)
 Motor Cover Thickness = 0.040 (1.0)
 Curb Cap Thickness = 0.064 (1.6)
 ^Approximate Unit Weight = 138 lb (636363 kg)

All dimensions in inches (millimeters). *May be greater depending on motor.
 ^Weight shown is largest cataloged Open Drip-Proof motor.

Model Number	Motor HP	Fan RPM		Static Pressure in Inches wg											
				0	0.125	0.25	0.375	0.5	0.75	1	1.25	1.5	1.75		
200-4	1/4	440	CFM	2435	1976										
			BHP	0.10	0.10										
			Sones	6.5	5.8										
		600	CFM	3320	2984	2637	2089								
			BHP	0.25	0.26	0.26	0.25								
			Sones	8.5	7.9	7.3	6.1								
200-3	1/3	665	CFM	3680	3378	3085	2706	2087							
			BHP	0.34	0.34	0.36	0.35	0.33							
			Sones	9.6	9.0	8.5	7.7	6.7							
200-5	1/2	718	CFM	3973	3700	3422	3109	2684							
			BHP	0.43	0.43	0.45	0.45	0.44							
			Sones	10.8	10.0	9.6	9.0	8.3							
		770	CFM	4261	4013	3744	3477	3141							
			BHP	0.53	0.53	0.55	0.55	0.55							
			Sones	12.1	11.0	10.7	10.2	9.8							
200-7	3/4	860	CFM	4759	4548	4289	4068	3811	3085						
			BHP	0.73	0.74	0.75	0.77	0.77	0.74						
			Sones	14.1	13.3	12.9	12.4	11.8	11.1						
200-10	1	965	CFM	5340	5158	4927	4720	4520	4015	3240					
			BHP	1.03	1.04	1.05	1.08	1.09	1.08	1.02					
			Sones	16.7	16.0	15.4	15.0	14.5	13.7	13.0					
200-15	1½	1028	CFM	5689	5517	5309	5101	4918	4488	3911	2941				
			BHP	1.25	1.26	1.27	1.29	1.31	1.32	1.29	1.14				
			Sones	18.5	17.8	17.2	16.8	16.4	15.6	14.7	14.6				
		1090	CFM	6032	5870	5682	5473	5301	4925	4450	3751				
			BHP	1.49	1.50	1.51	1.52	1.56	1.56	1.56	1.48				
			Sones	20	19.6	18.9	18.4	18.1	17.5	16.8	15.8				
200-20	2	1145	CFM	6336	6182	6010	5809	5637	5299	4870	4333	3517			
			BHP	1.73	1.74	1.75	1.76	1.79	1.81	1.82	1.77	1.64			
			Sones	22	21	21	20	19.8	19.2	18.7	17.7	16.6			
		1200	CFM	6640	6494	6336	6145	5969	5651	5274	4829	4177	3077		
			BHP	1.99	2.00	2.01	2.02	2.04	2.09	2.09	2.08	1.96	1.69		
			Sones	24	23	23	22	22	21	21	19.9	18.6	16.7		

Performance certified is for installation type A: Free inlet, Free outlet. Power rating (BHP) does not include transmission losses. Performance ratings include the effects of a birdscreen. The sound ratings shown are loudness values in hemispherical sones at 5 ft. (1.5 m) in a hemispherical free field calculated per AMCA Standard 301. Values shown are for installation type A: free inlet hemispherical sone levels.

Roof Downblast - Belt Drive GB-200HP

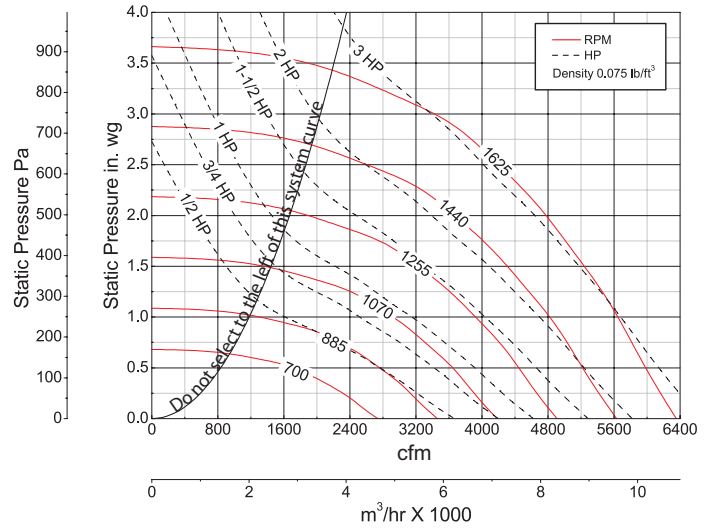
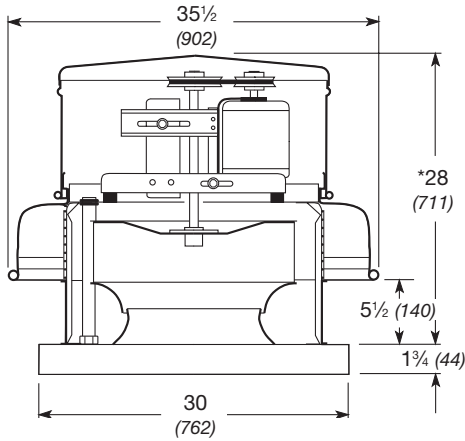

- Damper Size = 18 x 18 (457 x 457)
- Roof Opening = 20½ x 20½ (521 x 521)
- Shroud Thickness = 0.064 (1.6)
- Motor Cover Thickness = 0.040 (1.0)
- Curb Cap Thickness = 0.064 (1.6)
- ^Approximate Unit Weight = 138 lb (63 kg)

All dimensions in inches (millimeters). *May be greater depending on motor.
^Weight shown is largest cataloged Open Drip-Proof motor.

Model Number	Motor HP	Fan RPM		Static Pressure in Inches wg																	
				0.5	0.75	1	1.25	1.5	2	2.5	2.75	3	3.25								
200HP-5	1/2	740	CFM	1961																	
			BHP	0.30																	
			Sones	8.7																	
		895	CFM	2809	2331	1424															
			BHP	0.52	0.53	0.45															
			Sones	11.4	10.9	10.3															
200HP-7	3/4	958	CFM	3116	2715	2153															
			BHP	0.63	0.65	0.63															
			Sones	12.8	12.1	11.6															
		1020	CFM	3409	3050	2602	1857														
			BHP	0.75	0.77	0.78	0.71														
			Sones	14.1	13.6	13.1	12.6														
200HP-10	1	1125	CFM	3885	3584	3243	2804	2136													
			BHP	0.99	1.02	1.04	1.04	0.97													
			Sones	16.9	16.4	15.5	15.3	15.2													
200HP-15	1½	1205	CFM	4229	3967	3663	3314	2884													
			BHP	1.19	1.24	1.27	1.29	1.27													
			Sones	18.8	17.9	17.2	16.5	16.4													
		1285	CFM	4569	4343	4070	3770	3416	2278												
			BHP	1.43	1.49	1.52	1.55	1.57	1.40												
			Sones	21	20	19.1	18.1	17.8	18.9												
200HP-20	2	1350	CFM	4843	4638	4384	4109	3811	2996												
			BHP	1.65	1.71	1.75	1.78	1.81	1.76												
			Sones	23	22	21	19.8	19.3	19.1												
		1415	CFM	5114	4919	4692	4442	4169	3492	2250											
			BHP	1.88	1.95	2.00	2.04	2.07	2.07	1.78											
			Sones	24	24	23	22	21	19.7	23											
200HP-30	3	1520	CFM	5550	5368	5182	4952	4713	4166	3458	2850	2046									
			BHP	2.31	2.38	2.45	2.50	2.53	2.58	2.53	2.38	2.06									
			Sones	27	27	27	26	24	23	22	22	22	22								
		1625	CFM	5982	5812	5642	5448	5233	4767	4196	3859	3377	2725								
			BHP	2.80	2.88	2.95	3.02	3.06	3.13	3.16	3.12	3.01	2.76								
			Sones	32	31	31	29	28	27	25	24	23	22								

Performance certified is for installation type A: Free inlet, Free outlet. Power rating (BHP) does not include transmission losses. Performance ratings include the effects of a birdscreen. The sound ratings shown are loudness values in hemispherical sones at 5 ft. (1.5 m) in a hemispherical free field calculated per AMCA Standard 301. Values shown are for installation type A: free inlet hemispherical sone levels.

Roof Downblast - Belt Drive GB-220

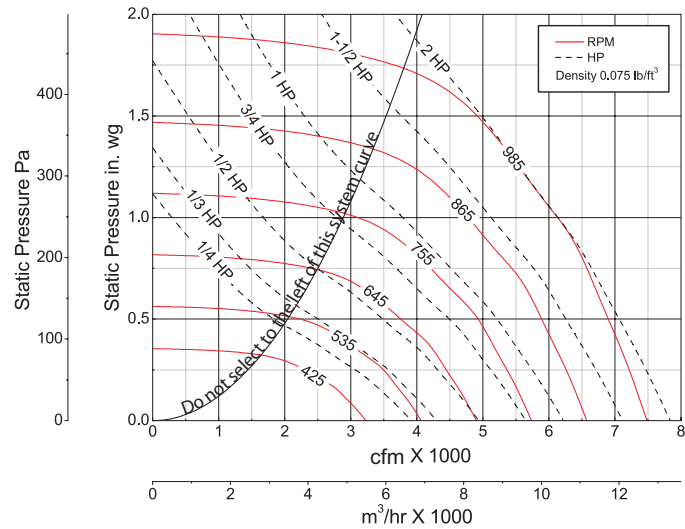
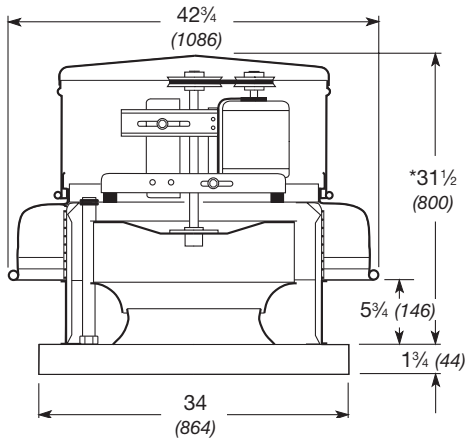

Damper Size = 24 x 24 (610 x 610)
 Roof Opening = 26 1/2 x 26 1/2 (673 x 673)
 Shroud Thickness = 0.064 (1.6)
 Motor Cover Thickness = 0.040 (1.0)
 Curb Cap Thickness = 0.064 (1.6)
 ^Approximate Unit Weight = 158 lb (72 kg)

All dimensions in inches (millimeters). *May be greater depending on motor.
 ^Weight shown is largest cataloged Open Drip-Proof motor.

Model Number	Motor HP	Fan RPM		Static Pressure in Inches wg																	
				0	0.125	0.25	0.375	0.5	0.625	0.75	1	1.25	1.5								
220-4	1/4	425	CFM	3230	2879	2296															
			BHP	0.14	0.16	0.16															
			Sones	7.4	7.2	6.9															
		465	CFM	3533	3219	2758	1951														
			BHP	0.18	0.20	0.21	0.19														
			Sones	8.1	7.8	7.4	7.0														
500	CFM	3799	3512	3132	2542																
	BHP	0.23	0.25	0.26	0.26																
	Sones	8.8	8.4	7.9	7.5																
220-3	1/3	550	CFM	4179	3924	3629	3158	2526													
			BHP	0.30	0.32	0.34	0.35	0.33													
			Sones	10.0	9.6	8.9	8.4	8.0													
220-5	1/2	640	CFM	4863	4654	4403	4120	3702	3208												
			BHP	0.48	0.50	0.53	0.54	0.55	0.54												
			Sones	13.0	12.8	12.1	11.2	10.5	9.7												
220-7	3/4	710	CFM	5395	5206	4990	4762	4459	4077	3633											
			BHP	0.65	0.68	0.71	0.73	0.74	0.75	0.74											
			Sones	15.0	14.9	14.4	13.6	12.8	12.1	11.2											
220-10	1	755	CFM	5737	5559	5362	5148	4920	4579	4206	3095										
			BHP	0.79	0.82	0.84	0.87	0.89	0.90	0.90	0.82										
			Sones	15.7	15.6	15.2	14.6	14.0	13.4	12.7	11.2										
		800	CFM	6079	5911	5732	5530	5326	5049	4716	3929										
			BHP	0.93	0.97	1.00	1.02	1.05	1.06	1.07	1.05										
			Sones	16.6	16.4	16.1	15.6	15.2	14.6	14.2	12.5										
220-15	1 1/2	848	CFM	6444	6286	6122	5932	5741	5540	5236	4566	3542									
			BHP	1.11	1.15	1.18	1.21	1.23	1.26	1.27	1.27	1.27	1.17								
			Sones	17.8	17.5	17.2	16.9	16.5	16.2	15.7	14.5	13.4									
		895	CFM	6801	6651	6501	6323	6142	5960	5723	5122	4401									
			BHP	1.31	1.34	1.38	1.41	1.44	1.47	1.49	1.50	1.47									
			Sones	19.4	19.1	18.8	18.5	18.2	18.0	17.6	16.9	15.5									
220-20	2	985	CFM	7485	7349	7212	7062	6898	6734	6568	6107	5548	4883								
			BHP	1.74	1.78	1.82	1.86	1.89	1.92	1.95	1.99	2.00	1.96								
			Sones	23	23	23	22	22	22	22	22	21	20	19.0							

Performance certified is for installation type A: Free inlet, Free outlet. Power rating (BHP) does not include transmission losses. Performance ratings include the effects of a birdscreen. The sound ratings shown are loudness values in hemispherical sones at 5 ft. (1.5 m) in a hemispherical free field calculated per AMCA Standard 301. Values shown are for installation type A: free inlet hemispherical sone levels.

Roof Downblast - Belt Drive GB-220HP

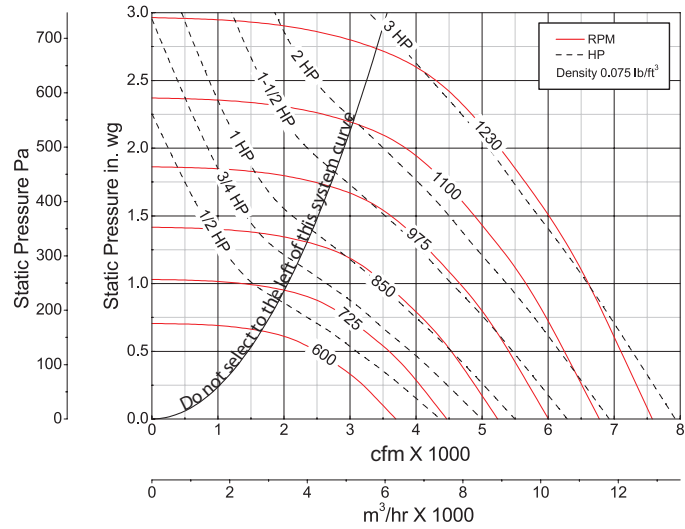
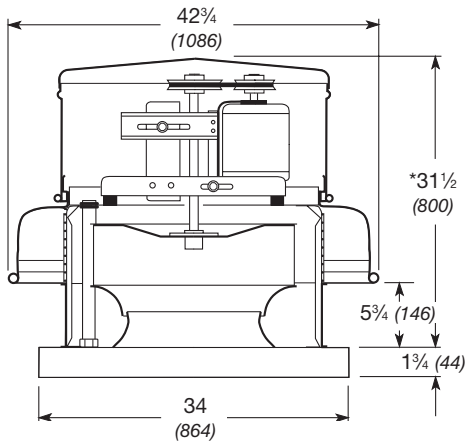

Damper Size = 24 x 24 (610 x 610)
 Roof Opening = $26\frac{1}{2}$ x $26\frac{1}{2}$ (673 x 673)
 Shroud Thickness = 0.064 (1.6)
 Motor Cover Thickness = 0.040 (1.0)
 Curb Cap Thickness = 0.064 (1.6)
 ^Approximate Unit Weight = 158 lb (72 kg)

All dimensions in inches (millimeters). *May be greater depending on motor.
 ^Weight shown is largest cataloged Open Drip-Proof motor.

Model Number	Motor HP	Fan RPM		Static Pressure in Inches wg																		
				0.5	0.625	0.75	1	1.25	1.5	1.75	2	2.25	2.5									
220HP-5	1/2	650	CFM	2952	2555	1892																
			BHP	0.47	0.46	0.42																
			Sones	8.9	8.5	8.3																
		680	CFM	3215	2871	2440																
			BHP	0.53	0.53	0.52																
			Sones	9.4	9.2	8.9																
220HP-7	3/4	728	CFM	3614	3312	2974																
			BHP	0.65	0.65	0.65																
			Sones	10.6	10.3	9.9																
		775	CFM	3973	3719	3424	2643															
			BHP	0.77	0.79	0.79	0.75															
			Sones	12.0	11.5	11.1	10.5															
220HP-10	1	850	CFM	4532	4317	4083	3536	2648														
			BHP	1.00	1.02	1.04	1.03	0.95														
			Sones	15.0	13.8	13.5	12.7	12.0														
220HP-15	1½	913	CFM	4975	4791	4590	4119	3545	2557													
			BHP	1.22	1.25	1.27	1.29	1.27	1.13													
			Sones	16.7	16.0	15.3	14.4	13.5	13.0													
		975	CFM	5400	5245	5060	4660	4185	3602													
			BHP	1.46	1.50	1.53	1.57	1.56	1.53													
			Sones	18.7	18.2	17.5	16.3	15.4	14.8													
220HP-20	2	1025	CFM	5740	5591	5432	5075	4643	4157	3492												
			BHP	1.68	1.72	1.76	1.81	1.82	1.804	1.74												
			Sones	21	20	19.4	18.2	17.1	16.4	15.6												
		1075	CFM	6076	5935	5794	5459	5082	4649	4136	3346											
			BHP	1.93	1.97	2.01	2.06	2.10	2.10	2.07	1.93											
			Sones	23	22	21	20	18.7	18.3	17.7	16.4											
220HP-30	3	1127	CFM	6422	6289	6154	5852	5520	5124	4703	4173	3299										
			BHP	2.20	2.24	2.29	2.36	2.41	2.42	2.41	2.37	2.17										
			Sones	24	24	23	22	21	20	19.3	18.6	17.7										
		1230	CFM	7100	6981	6858	6611	6316	6009	5649	5263	4812	4265									
			BHP	2.82	2.87	2.92	3.01	3.08	3.14	3.15	3.14	3.10	3.02									
			Sones	28	27	27	27	25	25	23	22	22	22									

Performance certified is for installation type A: Free inlet, Free outlet. Power rating (BHP) does not include transmission losses. Performance ratings include the effects of a birdscreen. The sound ratings shown are loudness values in hemispherical sones at 5 ft. (1.5 m) in a hemispherical free field calculated per AMCA Standard 301. Values shown are for installation type A: free inlet hemispherical sone levels.

Roof Downblast - Belt Drive GB-240

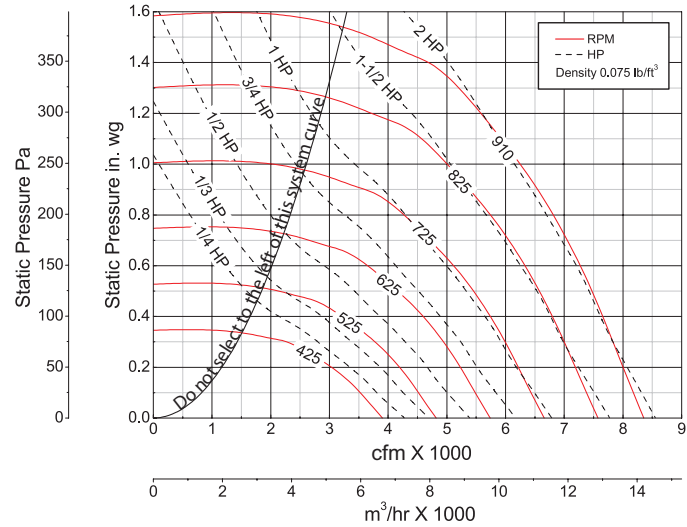
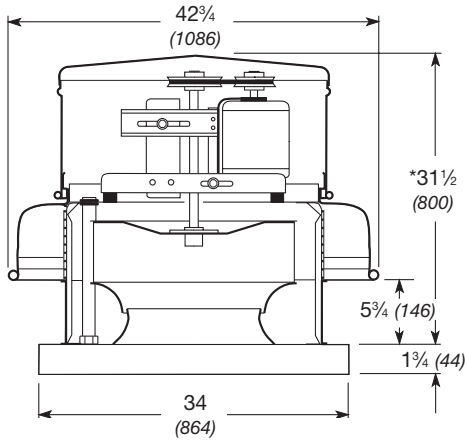

Damper Size = 24 x 24 (610 x 610)
 Roof Opening = 26½ x 26½ (673 x 673)
 Shroud Thickness = 0.064 (1.6)
 Motor Cover Thickness = 0.040 (1.0)
 Curb Cap Thickness = 0.064 (1.6)
 ^Approximate Unit Weight = 158 lb (72 kg)

All dimensions in inches (millimeters). *May be greater depending on motor.
 ^Weight shown is largest cataloged Open Drip-Proof motor.

Model Number	Motor HP	Fan RPM		Static Pressure in Inches wg															
				0	0.125	0.25	0.375	0.5	0.625	0.75	1	1.25	1.5						
240-4	1/4	425	CFM	3902	3422	2691													
			BHP	0.19	0.21	0.20													
			Sones	5.9	5.9	4.7													
		460	CFM	4223	3785	3188	2036												
			BHP	0.24	0.26	0.27	0.22												
			Sones	6.7	6.6	5.7	4.2												
240-3	1/3	505	CFM	4637	4242	3761	3060												
			BHP	0.32	0.35	0.35	0.34												
			Sones	7.8	7.5	6.9	6.1												
240-5	1/2	585	CFM	5371	5031	4666	4195	3562	2112										
			BHP	0.50	0.53	0.54	0.55	0.53	0.41										
			Sones	10.3	9.7	9.1	8.8	8.2	7.2										
240-7	3/4	623	CFM	5720	5400	5069	4660	4131	3428										
			BHP	0.60	0.64	0.65	0.66	0.65	0.61										
			Sones	11.7	11.0	10.4	10.0	9.6	9.1										
		660	CFM	6060	5757	5449	5094	4636	4073	3217									
			BHP	0.71	0.75	0.78	0.79	0.78	0.76	0.69									
			Sones	13.1	12.4	11.8	11.3	11.0	10.6	10.4									
240-10	1	730	CFM	6702	6428	6158	5861	5507	5077	4568									
			BHP	0.96	1.01	1.05	1.05	1.06	1.06	1.03									
			Sones	15.8	15.0	14.3	13.8	13.4	13.1	12.9									
240-15	1½	778	CFM	7143	6886	6632	6363	6058	5700	5266	4145								
			BHP	1.16	1.21	1.26	1.27	1.28	1.29	1.28	1.18								
			Sones	17.7	16.6	15.9	15.4	15.0	14.7	14.4	13.2								
		825	CFM	7575	7332	7092	6844	6574	6261	5901	5002								
			BHP	1.39	1.44	1.49	1.51	1.52	1.54	1.53	1.48								
			Sones	19.7	18.6	17.7	17.2	16.8	16.4	16.2	14.8								
240-20	2	870	CFM	7988	7757	7529	7300	7055	6775	6457	5680	7757							
			BHP	1.63	1.68	1.73	1.77	1.78	1.80	1.80	1.77	1.68							
			Sones	22	21	19.6	19.1	18.7	18.3	17.9	16.9	21							
		910	CFM	8355	8135	7916	7700	7467	7215	6933	6240	5388	3707						
			BHP	1.86	1.92	1.97	2.02	2.03	2.05	2.06	2.05	1.97	1.66						
			Sones	24	23	21	21	21	20	19.6	19.2	16.7	13.6						

Performance certified is for installation type A: Free inlet, Free outlet. Power rating (BHP) does not include transmission losses. Performance ratings include the effects of a birdscreen. The sound ratings shown are loudness values in hemispherical sones at 5 ft. (1.5 m) in a hemispherical free field calculated per AMCA Standard 301. Values shown are for installation type A: free inlet hemispherical sone levels.

Roof Downblast - Belt Drive GB-240HP

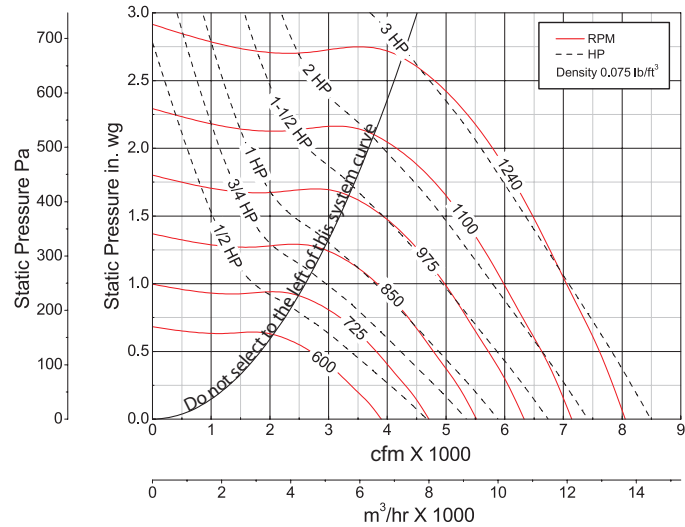
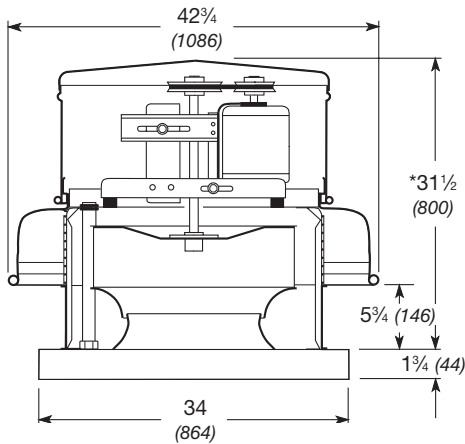

Damper Size = 24 x 24 (610 x 610)
 Roof Opening = 26 1/2 x 26 1/2 (673 x 673)
 Shroud Thickness = 0.064 (1.6)
 Motor Cover Thickness = 0.040 (1.0)
 Curb Cap Thickness = 0.064 (1.6)
 ^Approximate Unit Weight = 158 lb (72 kg)

All dimensions in inches (millimeters). *May be greater depending on motor.
 ^Weight shown is largest cataloged Open Drip-Proof motor.

Model Number	Motor HP	Fan RPM		Static Pressure in Inches wg											
				0.5	0.625	0.75	1	1.25	1.5	1.75	2	2.25	2.5		
240HP-5	1/2	635	CFM	3035	2586										
			BHP	0.42	0.41										
			Sones	8.0	7.6										
		685	CFM	3475	3147	2693									
			BHP	0.53	0.53	0.51									
			Sones	9.4	8.8	8.4									
240HP-7	3/4	733	CFM	3877	3603	3272									
			BHP	0.64	0.65	0.65									
			Sones	11.0	10.3	9.7									
		780	CFM	4247	4005	3740	2964								
			BHP	0.76	0.77	0.78	0.75								
			Sones	12.7	11.9	11.3	10.3								
240HP-10	1	860	CFM	4860	4654	4434	3915	3105							
			BHP	0.99	1.02	1.04	1.05	0.99							
			Sones	15.9	15.2	14.3	13.2	12.2							
240HP-15	1 1/2	920	CFM	5310	5118	4925	4496	3944							
			BHP	1.20	1.23	1.25	1.29	1.27							
			Sones	18.5	17.4	16.6	15.0	13.8							
		980	CFM	5751	5574	5392	5010	4562	3958						
			BHP	1.43	1.47	1.49	1.54	1.55	1.52						
			Sones	22	19.9	19.1	17.2	15.6	14.8						
240HP-20	2	1030	CFM	6114	5948	5776	5428	5039	4560	3896					
			BHP	1.65	1.69	1.72	1.77	1.80	1.80	1.73					
			Sones	24	23	21	19.6	17.6	16.3	15.7					
		1080	CFM	6474	6315	6154	5826	5468	5062	4555	3763				
			BHP	1.89	1.92	1.96	2.02	2.06	2.08	2.05	1.93				
			Sones	27	26	24	23	20	18.2	17.3	16.7				
240HP-30	3	1133	CFM	6853	6702	6550	6237	5914	5560	5133	4588				
			BHP	2.16	2.20	2.24	2.31	2.36	2.40	2.39	2.35				
			Sones	29	27	26	24	22	21	19.3	18.7				
		1240	CFM	7610	7471	7333	7053	6767	6469	6146	5775	5364	4776		
			BHP	2.80	2.84	2.89	2.97	3.04	3.10	3.14	3.14	3.13	3.04		
			Sones	31	30	29	28	27	25	24	23	23	22		

MAXIMUM BHP AT A GIVEN RPM = (RPM/845)³
 MAXIMUM RPM = 1240
 TIP SPEED (ft/min) = RPM x 6.414
 MAXIMUM MOTOR FRAME SIZE = 184T

Performance certified is for installation type A: Free inlet, Free outlet. Power rating (BHP) does not include transmission losses. Performance ratings include the effects of a birdscreen. The sound ratings shown are loudness values in hemispherical sones at 5 ft. (1.5 m) in a hemispherical free field calculated per AMCA Standard 301. Values shown are for installation type A: free inlet hemispherical sone levels.

Roof Downblast - Belt Drive GB-260

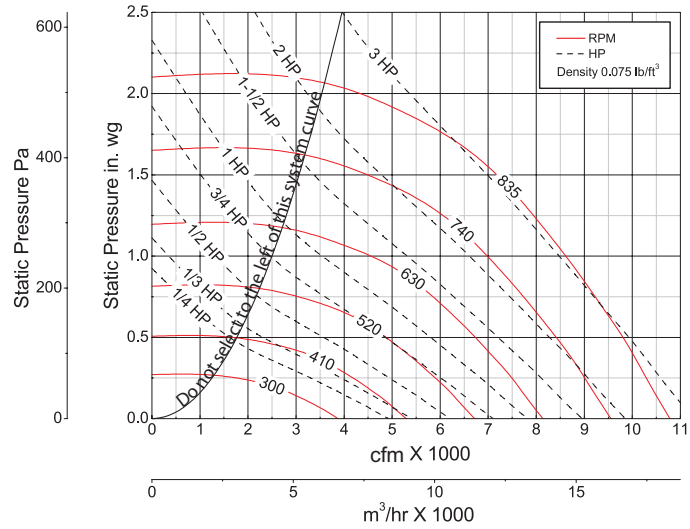
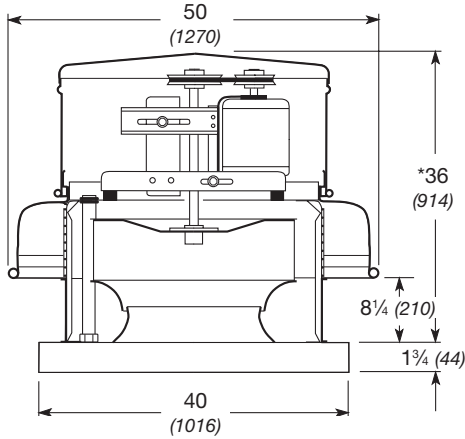

Damper Size = 30 x 30 (762 x 762)
 Roof Opening = 32½ x 32½ (826 x 826)
 Shroud Thickness = 0.064 (1.6)
 Motor Cover Thickness = 0.051 (1.3)
 Curb Cap Thickness = 0.064 (1.6)
 ^Approximate Unit Weight = 305 lb (138 kg)

All dimensions in inches (millimeters). *May be greater depending on motor.
 ^Weight shown is largest cataloged Open Drip-Proof motor.

Model Number	Motor HP	Fan RPM		Static Pressure in Inches wg													
				0	0.125	0.25	0.5	0.75	1	1.25	1.5	1.75	2				
260-4	1/4	300	CFM	3875	3121	1727											
			BHP	0.12	0.14	0.12											
			Sones	8.0	7.1	7.4											
		365	CFM	4714	4130	3393											
			BHP	0.22	0.25	0.26											
			Sones	9.2	8.8	8.6											
260-3	1/3	405	CFM	5231	4716	4095											
			BHP	0.30	0.33	0.35											
			Sones	10.4	10.3	10.3											
260-5	1/2	465	CFM	6005	5570	5063	3745										
			BHP	0.45	0.50	0.52	0.53										
			Sones	11.4	10.9	10.4	9.6										
260-7	3/4	520	CFM	6716	6324	5898	4869	3008									
			BHP	0.63	0.68	0.72	0.75	0.64									
			Sones	12.9	12.1	11.3	10.3	9.4									
260-10	1	580	CFM	7491	7137	6775	5912	4826									
			BHP	0.88	0.93	0.98	1.04	1.03									
			Sones	14.4	13.7	13.0	12.2	11.0									
260-15	1½	665	CFM	8588	8278	7979	7274	6474	5465	3608							
			BHP	1.33	1.39	1.44	1.53	1.57	1.55	1.29							
			Sones	16.7	16.2	15.8	15.0	14.2	13.3	12.8							
260-20	2	700	CFM	9041	8746	8460	7811	7068	6227	4912							
			BHP	1.55	1.61	1.67	1.77	1.82	1.83	1.71							
			Sones	17.8	17.4	17.0	16.2	15.5	14.8	13.8							
		735	CFM	9493	9212	8938	8335	7649	6878	5916	4236						
			BHP	1.79	1.86	1.92	2.03	2.10	2.13	2.09	1.80						
			Sones	18.9	18.6	18.3	17.6	16.8	16.2	15.6	14.9						
260-30	3	785	CFM	10138	9875	9617	9069	8452	7769	7006	5949	4189					
			BHP	2.18	2.26	2.33	2.44	2.53	2.58	2.59	2.49	2.11					
			Sones	21	20	20	19.7	18.9	18.2	17.9	17.1	16.7					
		835	CFM	10784	10537	10292	9794	9225	8606	7932	7157	6024	4294				
			BHP	2.62	2.70	2.78	2.91	3.02	3.08	3.12	3.10	2.93	2.49				
			Sones	23	23	22	22	21	20	19.9	19.7	18.7	18.6				

Performance certified is for installation type A: Free inlet, Free outlet. Power rating (BHP) does not include transmission losses. Performance ratings include the effects of a birdscreen. The sound ratings shown are loudness values in hemispherical sones at 5 ft. (1.5 m) in a hemispherical free field calculated per AMCA Standard 301. Values shown are for installation type A: free inlet hemispherical sone levels.

Roof Downblast - Belt Drive GB-300

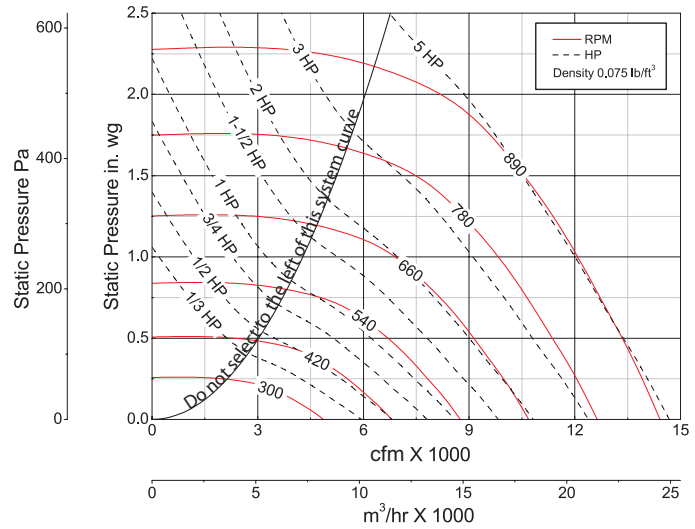
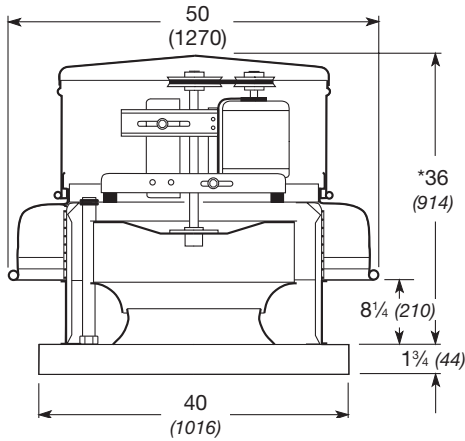

Damper Size = 30 x 30 (762 x 762)
 Roof Opening = 32 1/2 x 32 1/2 (826 x 826)
 Shroud Thickness = 0.064 (1.6)
 Motor Cover Thickness = 0.051 (1.3)
 Curb Cap Thickness = 0.064 (1.6)
 ^Approximate Unit Weight = 320 lb (145 kg)

All dimensions in inches (millimeters). *May be greater depending on motor.
 ^Weight shown is largest cataloged Open Drip-Proof motor.

Model Number	Motor HP	Fan RPM		Static Pressure in Inches wg																	
				0	0.125	0.25	0.5	0.75	1	1.25	1.5	1.75	2								
300-3	1/3	300	CFM	4859	3976																
			BHP	0.18	0.19																
			Sones	9.3	5.3																
		365	CFM	5912	5222	4340															
			BHP	0.33	0.35	0.35															
			Sones	9.2	6.2	5.7															
300-5	1/2	420	CFM	6803	6222	5537															
			BHP	0.50	0.52	0.53															
			Sones	9.6	8.0	7.0															
300-7	3/4	475	CFM	7694	7197	6616	5095														
			BHP	0.72	0.75	0.77	0.74														
			Sones	11.4	10.6	9.6	8.1														
300-10	1	530	CFM	8585	8150	7640	6456	4195													
			BHP	1.00	1.04	1.06	1.07	0.91													
			Sones	13.4	12.9	12.2	10.7	9.4													
300-15	1 1/2	600	CFM	9719	9334	8907	7952	6721													
			BHP	1.45	1.49	1.53	1.55	1.52													
			Sones	15.9	15.4	14.9	13.8	12.2													
300-20	2	665	CFM	10772	10425	10060	9228	8269	7025												
			BHP	1.97	2.02	2.06	2.11	2.11	2.03												
			Sones	18.8	18.2	17.7	16.8	15.7	13.7												
300-30	3	713	CFM	11549	11226	10901	10129	9297	8283	6691											
			BHP	2.43	2.48	2.53	2.59	2.61	2.57	2.38											
			Sones	21	20	19.6	18.9	18.0	16.4	13.7											
		760	CFM	12311	12007	11704	10997	10242	9369	8293	6437										
			BHP	2.94	3.00	3.05	3.13	3.16	3.15	3.06	2.76										
			Sones	23	22	21	21	19.8	18.6	16.8	14.0										
300-50	5	825	CFM	13363	13084	12804	12175	11501	10770	9909	8885	7128									
			BHP	3.76	3.82	3.88	3.97	4.02	4.05	4.01	3.90	3.56									
			Sones	25	25	24	24	23	22	20	18.7	16.1									
		890	CFM	14416	14157	13898	13335	12716	12073	11379	10536	9568	7963								
			BHP	4.73	4.79	4.85	4.96	5.03	5.06	5.09	5.02	4.89	4.54								
			Sones	28	28	28	27	26	25	24	22	21	18.7								

Performance certified is for installation type A: Free inlet, Free outlet. Power rating (BHP) does not include transmission losses. Performance ratings include the effects of a birdscreen. The sound ratings shown are loudness values in hemispherical sones at 5 ft. (1.5 m) in a hemispherical free field calculated per AMCA Standard 301. Values shown are for installation type A: free inlet hemispherical sone levels.

Roof Downblast - Belt Drive GB-300HP

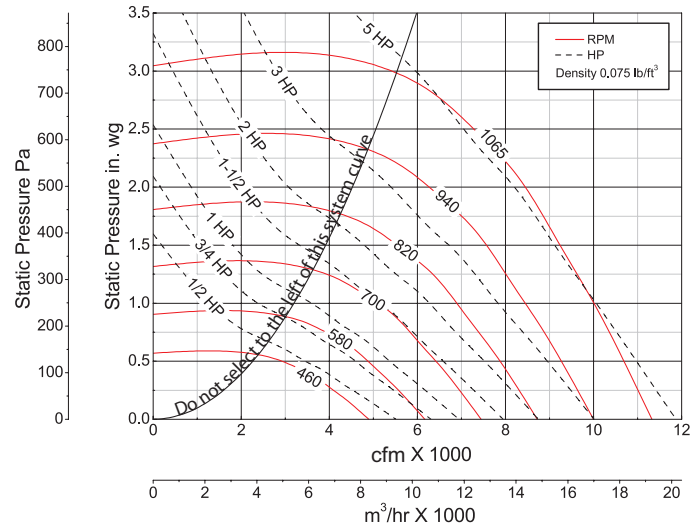
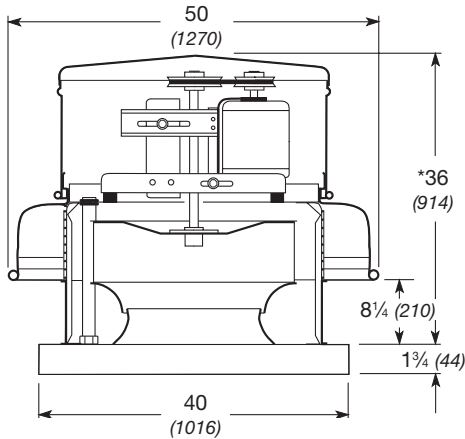

Damper Size = 30 x 30 (762 x 762)
 Roof Opening = 32½ x 32½ (826 x 826)
 Shroud Thickness = 0.064 (1.6)
 Motor Cover Thickness = 0.051 (1.3)
 Curb Cap Thickness = 0.064 (1.6)
 ^Approximate Unit Weight = 320 lb (145 kg)

All dimensions in inches (millimeters). *May be greater depending on motor.
 ^Weight shown is largest cataloged Open Drip-Proof motor.

Model Number	Motor HP	Fan RPM		Static Pressure in Inches wg																		
				0.5	0.75	1	1.25	1.5	1.75	2	2.25	2.5	2.75									
300HP-5	1/2	460	CFM	2912																		
			BHP	0.41																		
			Sones	9.7																		
		495	CFM	3602																		
			BHP	0.53																		
			Sones	10.3																		
300HP-7	3/4	565	CFM	4662	3600																	
			BHP	0.77	0.76																	
			Sones	11.8	10.4																	
300HP-10	1	620	CFM	5398	4652	3309																
			BHP	1.01	1.04	0.94																
			Sones	13.4	12.3	10.6																
300HP-15	1½	710	CFM	6542	5954	5269	4221															
			BHP	1.48	1.53	1.55	1.47															
			Sones	17.2	16.0	15.3	13.4															
300HP-20	2	748	CFM	7013	6462	5889	5027															
			BHP	1.71	1.78	1.81	1.78															
			Sones	18.8	17.5	17.0	15.7															
		785	CFM	7460	6943	6402	5737	4800														
			BHP	1.96	2.04	2.08	2.10	2.00														
			Sones	20	19.1	18.5	17.9	16.2														
300HP-30	3	840	CFM	8107	7642	7146	6636	5922	4992													
			BHP	2.37	2.46	2.52	2.57	2.56	2.43													
			Sones	23	22	21	21	19.7	18.0													
		895	CFM	8746	8328	7870	7394	6892	6150	5245												
			BHP	2.84	2.95	3.03	3.07	3.11	3.08	2.92												
			Sones	25	24	23	23	23	22	19.8												
300HP-50	5	980	CFM	9722	9356	8951	8531	8094	7657	7029	6264	5222										
			BHP	3.68	3.81	3.90	3.99	4.03	4.08	4.09	3.95	3.69										
			Sones	32	31	29	28	27	26	25	24	23										
		1065	CFM	10688	10351	10006	9621	9233	8831	8429	7903	7255	6543									
			BHP	4.67	4.81	4.94	5.04	5.12	5.17	5.23	5.24	5.17	5.01									
			Sones	44	42	37	37	36	35	33	31	30	29									

MAXIMUM BHP AT A GIVEN RPM = (RPM/613)³
 MAXIMUM RPM = 1065
 TIP SPEED (ft/min) = RPM x 7.985
 MAXIMUM MOTOR FRAME SIZE = 184T

Performance certified is for installation type A: Free inlet, Free outlet. Power rating (BHP) does not include transmission losses. Performance ratings include the effects of a birdscreen. The sound ratings shown are loudness values in hemispherical sones at 5 ft. (1.5 m) in a hemispherical free field calculated per AMCA Standard 301. Values shown are for installation type A: free inlet hemispherical sone levels.

Roof Downblast - Belt Drive GB-330

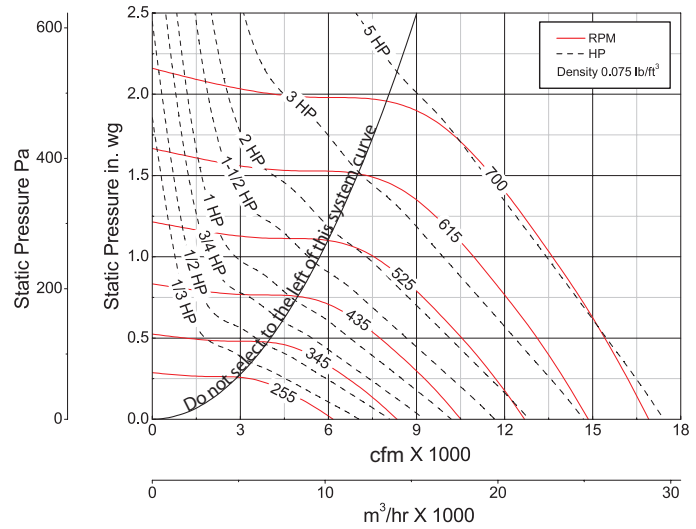
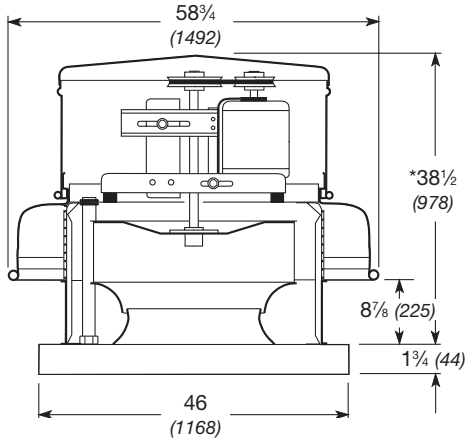

Damper Size = 36 x 36 (914 x 914)
 Roof Opening = 38½ x 38½ (978 x 978)
 Shroud Thickness = 0.080 (2.0)
 Motor Cover Thickness = 0.064 (1.6)
 Curb Cap Thickness = 0.080 (2.0)
 ^Approximate Unit Weight = 385 lb (175 kg)

All dimensions in inches (millimeters). *May be greater depending on motor.
 ^Weight shown is largest cataloged Open Drip-Proof motor.

Model Number	Motor HP	Fan RPM		Static Pressure in Inches wg													
				0	0.125	0.25	0.375	0.5	0.75	1	1.25	1.5	1.75				
330-3	1/3	255	CFM	6159	5043	3236											
			BHP	0.22	0.25	0.22											
			Sones	5.2	4.9	4.8											
		275	CFM	6643	5633	4308											
			BHP	0.28	0.31	0.31											
			Sones	5.9	5.5	5.2											
330-5	1/2	325	CFM	7850	7029	6036	4757										
			BHP	0.46	0.50	0.52	0.50										
			Sones	8.5	8.3	7.4	7.1										
330-7	3/4	370	CFM	8937	8232	7410	6480	5257									
			BHP	0.68	0.73	0.76	0.76	0.72									
			Sones	10.2	9.8	9.2	8.4	8.3									
330-10	1	415	CFM	10024	9401	8713	7927	7050									
			BHP	0.95	1.01	1.06	1.07	1.07									
			Sones	12.6	11.9	11.3	10.6	10.0									
330-15	1½	465	CFM	11232	10683	10087	9425	8706	6966								
			BHP	1.34	1.40	1.46	1.50	1.51	1.46								
			Sones	15.1	14.6	14.0	13.4	12.8	11.7								
330-20	2	510	CFM	12319	11824	11294	10719	10085	8696	6472							
			BHP	1.77	1.84	1.91	1.96	1.98	1.99	1.79							
			Sones	17.7	17.2	16.6	16.1	15.6	14.4	13.9							
330-30	3	550	CFM	13285	12828	12340	11822	11266	10041	8616							
			BHP	2.22	2.29	2.37	2.43	2.47	2.51	2.46							
			Sones	19.6	19.2	18.7	18.2	17.7	16.7	15.7							
		590	CFM	14251	13825	13376	12908	12408	11307	10081	8536						
			BHP	2.74	2.82	2.90	2.98	3.03	3.09	3.08	2.95						
			Sones	22	21	21	20	19.8	18.8	17.7	17.1						
330-50	5	645	CFM	15580	15190	14786	14366	13922	12958	11912	10749	9292					
			BHP	3.57	3.66	3.75	3.84	3.91	4.00	4.04	4.01	3.85					
			Sones	24	24	24	23	23	22	21	20	19.4					
		700	CFM	16908	16549	16185	15798	15408	14564	13624	12640	11538	10184				
			BHP	4.57	4.66	4.761	4.86	4.95	5.08	5.14	5.17	5.12	4.94				
			Sones	28	27	27	27	27	26	25	24	23	22				

Performance certified is for installation type A: Free inlet, Free outlet. Power rating (BHP) does not include transmission losses. Performance ratings include the effects of a birdscreen. The sound ratings shown are loudness values in hemispherical sones at 5 ft. (1.5 m) in a hemispherical free field calculated per AMCA Standard 301. Values shown are for installation type A: free inlet hemispherical sone levels.

Roof Downblast - Belt Drive GB-360

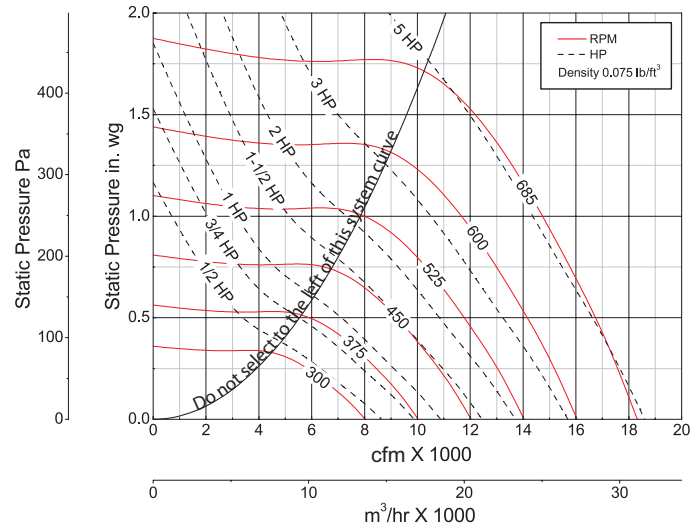
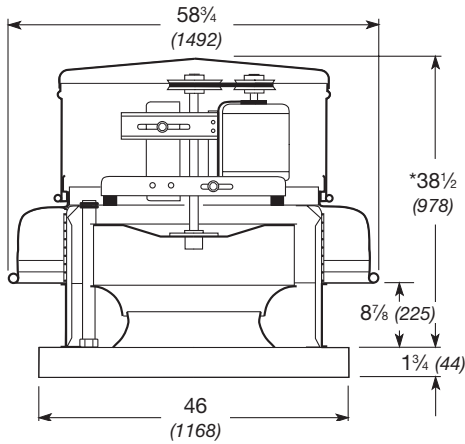

Damper Size = 36 x 36 (914 x 914)
 Roof Opening = 38 1/2 x 38 1/2 (978 x 978)
 Shroud Thickness = 0.080 (2.0)
 Motor Cover Thickness = 0.064 (1.6)
 Curb Cap Thickness = 0.080 (2.0)
 ^Approximate Unit Weight = 403 lb (183 kg)

All dimensions in inches (millimeters). *May be greater depending on motor.
 ^Weight shown is largest cataloged Open Drip-Proof motor.

Model Number	Motor HP	Fan RPM	Static Pressure in Inches wg													
			0	0.125	0.25	0.375	0.5	0.625	0.75	1	1.25	1.5				
360-5	1/2	300	CFM	8024	7070	5804										
			BHP	0.40	0.43	0.44										
			Sones	7.6	6.6	5.6										
		325	CFM	8693	7830	6756	5001									
			BHP	0.51	0.54	0.56	0.51									
			Sones	8.7	7.7	6.8	5.6									
360-7	3/4	365	CFM	9763	9024	8109	7013									
			BHP	0.72	0.76	0.79	0.78									
			Sones	10.8	10.0	8.9	7.9									
360-10	1	410	CFM	10966	10330	9558	8686	7641								
			BHP	1.02	1.07	1.11	1.12	1.11								
			Sones	13.7	13.3	11.9	10.9	9.6								
360-15	1 1/2	460	CFM	12304	11737	11085	10360	9568	8607	7096						
			BHP	1.45	1.50	1.55	1.58	1.59	1.56	1.46						
			Sones	15.9	15.6	14.8	14.1	13.1	12.1	10.9						
360-20	2	483	CFM	12919	12379	11776	11109	10355	9517	8488						
			BHP	1.67	1.73	1.78	1.82	1.83	1.83	1.78						
			Sones	17.0	16.7	16.1	15.5	14.8	13.7	12.9						
		505	CFM	13507	12991	12431	11795	11096	10368	9473						
			BHP	1.91	1.97	2.02	2.07	2.09	2.10	2.07						
			Sones	18.1	17.8	17.3	16.8	16.5	15.5	14.7						
360-30	3	543	CFM	14524	14043	13551	12959	12350	11679	10965	8917					
			BHP	2.38	2.44	2.5	2.55	2.59	2.60	2.60	2.46					
			Sones	20	19.8	19.4	18.9	18.6	17.8	16.9	15.6					
		580	CFM	15513	15064	14614	14077	13523	12917	12289	10813					
			BHP	2.90	2.96	3.03	3.09	3.14	3.17	3.18	3.13					
			Sones	22	22	22	21	21	20	19.1	17.6					
360-50	5	633	CFM	16931	16519	16107	15654	15146	14639	14072	12892	11465				
			BHP	3.77	3.84	3.91	3.98	4.04	4.10	4.12	4.13	4.05				
			Sones	26	25	25	24	24	23	23	21	19.7				
		685	CFM	18322	17941	17560	17179	16711	16243	15774	14710	13535	12119			
			BHP	4.77	4.85	4.93	5.01	5.07	5.14	5.20	5.23	5.21	5.10			
			Sones	30	30	29	29	28	28	26	24	23	22			

Performance certified is for installation type A: Free inlet, Free outlet. Power rating (BHP) does not include transmission losses. Performance ratings include the effects of a birdscreen. The sound ratings shown are loudness values in hemispherical sones at 5 ft. (1.5 m) in a hemispherical free field calculated per AMCA Standard 301. Values shown are for installation type A: free inlet hemispherical sone levels.

Roof Downblast - Belt Drive GB-360HP

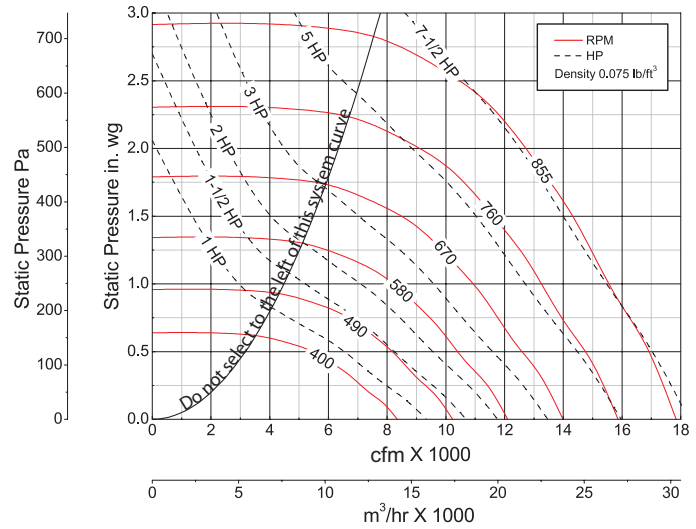
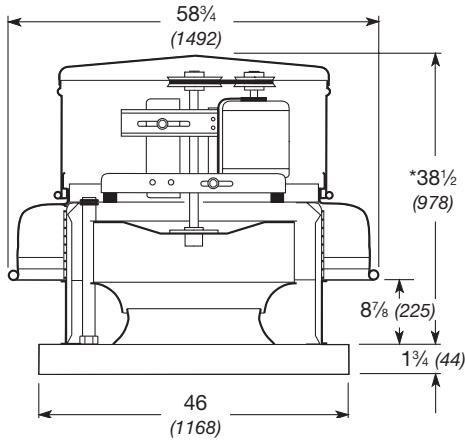

Damper Size = 36 x 36 (914 x 914)
 Roof Opening = 38½ x 38½ (978 x 978)
 Shroud Thickness = 0.080 (2.0)
 Motor Cover Thickness = 0.064 (1.6)
 Curb Cap Thickness = 0.080 (2.0)
 ^Approximate Unit Weight = 403 lb (183 kg)

All dimensions in inches (millimeters). *May be greater depending on motor.
 ^Weight shown is largest cataloged Open Drip-Proof motor.

Model Number	Motor HP	Fan RPM		Static Pressure in Inches wg																		
				0.5	0.75	1	1.25	1.5	1.75	2	2.25	2.5	2.75									
360HP-10	1	420	CFM	6097																		
			BHP	0.91																		
			Sones	10.4																		
		435	CFM	6576																		
			BHP	1.02																		
			Sones	10.8																		
360HP-15	1½	500	CFM	8432	7000																	
			BHP	1.56	1.53																	
			Sones	13.4	12.5																	
		525	CFM	9061	7808	5650																
			BHP	1.79	1.78	1.61																
			Sones	14.7	13.6	12.7																
360HP-20	2	550	CFM	9681	8589	6998																
			BHP	2.05	2.06	1.98																
			Sones	16.0	14.8	14.2																
		590	CFM	10657	9719	8495	6528															
			BHP	2.50	2.57	2.52	2.32															
			Sones	18.0	16.3	15.7	14.9															
360HP-30	3	630	CFM	11616	10772	9767	8525	6006														
			BHP	3.01	3.11	3.10	3.04	2.63														
			Sones	20	18.6	17.6	16.9	15.7														
		690	CFM	13062	12259	11464	10468	9335	7159													
			BHP	3.93	4.02	4.11	4.05	3.99	3.60													
			Sones	24	22	21	20	19.2	18.1													
360HP-50	5	750	CFM	14487	13711	13002	12220	11282	10239	8513												
			BHP	5.02	5.10	5.22	5.26	5.20	5.13	4.83												
			Sones	27	25	24	24	23	22	21												
		803	CFM	15728	14985	14309	13647	12863	11960	10986	9445											
			BHP	6.13	6.22	6.33	6.46	6.44	6.37	6.30	6.01											
			Sones	31	30	28	27	26	25	24	23											
360HP-75	7½	855	CFM	16918	16236	15568	14946	14315	13544	12676	11761	10368	8273									
			BHP	7.37	7.47	7.58	7.71	7.82	7.76	7.69	7.61	7.32	6.63									
			Sones	35	33	33	31	29	29	27	27	26	25									

Performance certified is for installation type A: Free inlet, Free outlet. Power rating (BHP) does not include transmission losses. Performance ratings include the effects of a birdscreen. The sound ratings shown are loudness values in hemispherical sones at 5 ft. (1.5 m) in a hemispherical free field calculated per AMCA Standard 301. Values shown are for installation type A: free inlet hemispherical sone levels.

Roof Downblast - Belt Drive GB-420

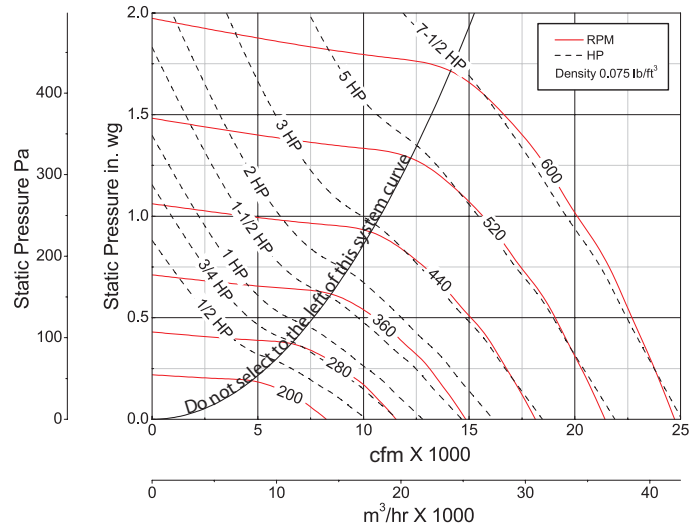
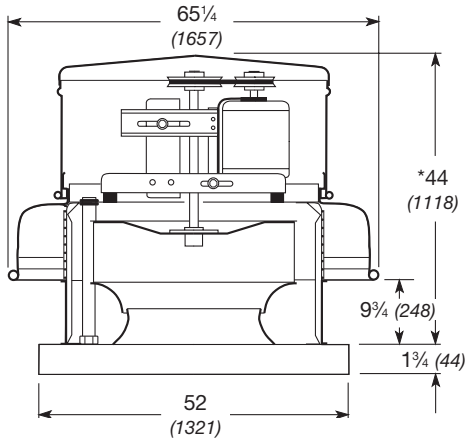

Damper Size = 42 x 42 (1067 x 1067)
 Roof Opening = 44½ x 44½ (1130 x 1130)
 Shroud Thickness = 0.080 (2.0)
 Motor Cover Thickness = 0.064 (1.6)
 Curb Cap Thickness = 0.100 (2.5)
 ^Approximate Unit Weight = 495 lb (225 kg)

All dimensions in inches (millimeters). *May be greater depending on motor.
 ^Weight shown is largest cataloged Open Drip-Proof motor.

Model Number	Motor HP	Fan RPM		Static Pressure in Inches wg													
				0	0.125	0.25	0.375	0.50	0.625	0.75	1.00	1.25	1.5				
420-5	1/2	200	CFM	8242	6454												
			BHP	0.27	0.29												
			Sones	3.1	2.9												
		240	CFM	9890	8573	6365											
			BHP	0.46	0.50	0.48											
			Sones	4.6	5.0	4.9											
420-7	3/4	275	CFM	11332	10219	8698											
			BHP	0.69	0.75	0.76											
			Sones	6.2	6.8	5.6											
420-10	1	305	CFM	12568	11579	10320	8672										
			BHP	0.95	1.01	1.03	1.01										
			Sones	8.0	8.4	7.5	7.2										
420-15	1½	345	CFM	14217	13357	12411	11102	9463									
			BHP	1.37	1.45	1.49	1.50	1.45									
			Sones	11.7	11.3	10.8	10.1	9.6									
420-20	2	380	CFM	15659	14892	14043	12983	11787	10108								
			BHP	1.83	1.92	1.97	2.00	2.00	1.91								
			Sones	14.4	13.8	13.3	12.7	12.3	12.0								
420-30	3	435	CFM	17925	17264	16540	15792	14790	13764	12502							
			BHP	2.74	2.86	2.93	2.97	2.99	2.95	2.95							
			Sones	19.0	18.4	17.8	17.3	16.6	16.4	16.5							
420-50	5	475	CFM	19574	18968	18320	17640	16887	15929	14994	12315						
			BHP	3.57	3.69	3.78	3.84	3.88	3.90	3.91	3.69						
			Sones	22	21	20	19.8	19.3	18.6	18.3	18.3						
		515	CFM	21222	20663	20081	19459	18826	18046	17162	15254	12312					
			BHP	4.55	4.68	4.80	4.87	4.92	4.95	4.98	4.92	4.56					
			Sones	24	24	23	22	21	21	20	19.4	19.1					
420-75	7½	558	CFM	22994	22478	21957	21383	20805	20219	19446	17835	15908					
			BHP	5.79	5.93	6.07	6.15	6.22	6.28	6.31	6.34	6.21					
			Sones	27	27	26	25	24	24	23	23	22					
		600	CFM	24725	24245	23765	23243	22709	22166	21621	20104	18585	16590				
			BHP	7.20	7.35	7.51	7.61	7.70	7.76	7.81	7.87	7.86	7.64				
			Sones	30	30	30	29	27	27	26	26	26	26				

MAXIMUM BHP AT A GIVEN RPM = (RPM/302)³
 MAXIMUM RPM = 600
 TIP SPEED (ft/min) = RPM x 11.061
 MAXIMUM MOTOR FRAME SIZE = 215T

Performance certified is for installation type A: Free inlet, Free outlet. Power rating (BHP) does not include transmission losses. Performance ratings include the effects of a birdscreen. The sound ratings shown are loudness values in hemispherical sones at 5 ft. (1.5 m) in a hemispherical free field calculated per AMCA Standard 301. Values shown are for installation type A: free inlet hemispherical sone levels.

Roof Downblast - Belt Drive GB-480

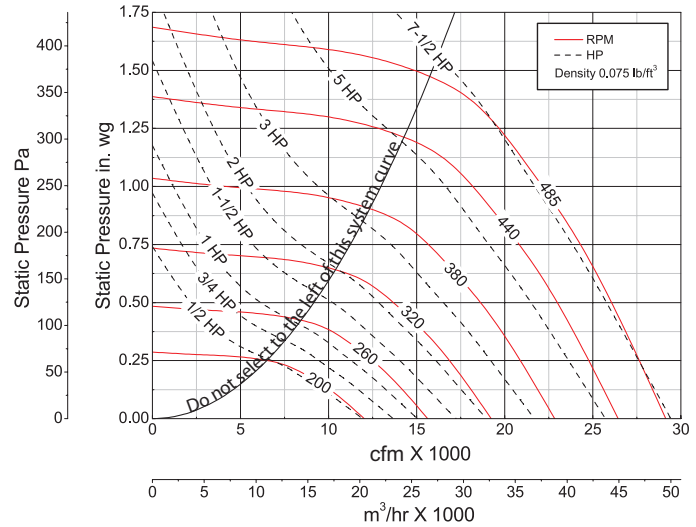
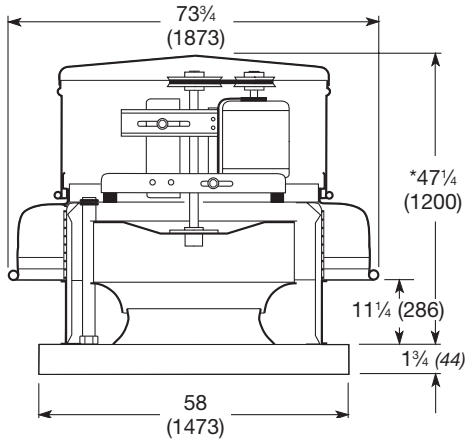

Damper Size = 48 x 48 (1219 x 1219)
 Roof Opening = 50 1/2 x 50 1/2 (1283 x 1283)
 Shroud Thickness = 0.080 (2.0)
 Motor Cover Thickness = 0.064 (1.6)
 Curb Cap Thickness = 0.100 (2.5)
 ^Approximate Unit Weight = 623 lb (283 kg)

All dimensions in inches (millimeters). *May be greater depending on motor.
 ^Weight shown is largest cataloged Open Drip-Proof motor.

Model Number	Motor HP	Fan RPM	Static Pressure in Inches wg												
			0	0.125	0.25	0.375	0.5	0.625	0.75	0.875	1	1.25			
480-5	1/2	200	CFM	12020	10059	6529									
			BHP	0.51	0.55	0.48									
			Sones	7.3	6.6	7.3									
480-7	3/4	225	CFM	13522	11811	9500									
			BHP	0.73	0.77	0.76									
			Sones	8.3	8.0	7.6									
480-10	1	250	CFM	15025	13516	11662	8820								
			BHP	1.00	1.05	1.06	0.98								
			Sones	9.5	9.5	8.6	8.1								
480-15	1 1/2	285	CFM	17129	15830	14379	12517	9587							
			BHP	1.48	1.54	1.58	1.56	1.42							
			Sones	11.8	11.2	10.7	10.0	9.1							
480-20	2	310	CFM	18631	17437	16135	14589	12656							
			BHP	1.90	1.97	2.02	2.02	1.97							
			Sones	14.0	13.0	12.2	12.0	11.5							
480-30	3	360	CFM	21636	20608	19548	18385	17010	15420	13507					
			BHP	2.98	3.06	3.13	3.17	3.17	3.21	3.00					
			Sones	17.6	17.0	16.4	15.9	15.5	15.0	14.2					
480-50	5	393	CFM	23619	22678	21736	20683	19605	18254	16764	15086				
			BHP	3.87	3.66	4.05	4.10	4.14	4.12	4.06	3.94				
			Sones	20	19.9	19.5	18.8	18.3	18.0	17.5	16.7				
	5	415	CFM	24942	24050	23158	22189	21181	20012	18733	17211	15486			
			BHP	4.56	4.65	4.75	4.81	4.85	4.86	4.84	4.74	4.58			
			Sones	22	22	22	21	21	20	20	19.1	18.1			
	5	425	CFM	25542	24672	23801	22868	21883	20799	19550	18156	16604			
			BHP	4.90	4.99	5.09	5.16	5.20	5.22	5.20	5.13	5.00			
			Sones	23	23	23	22	22	21	21	20	19.3			
480-75	7 1/2	455	CFM	27345	26532	25719	24886	23966	23046	21953	20786	19471	15870		
			BHP	6.01	6.11	6.22	6.31	6.36	6.41	6.41	6.38	6.30	5.85		
			Sones	27	27	27	26	26	25	25	24	24	21		
	7 1/2	485	CFM	29149	28386	27623	26860	26016	25153	24290	23201	22106	19517		
			BHP	7.28	7.39	7.50	7.61	7.67	7.72	7.78	7.75	7.73	7.49		
			Sones	31	31	31	31	30	29	29	28	28	26		

Performance certified is for installation type A: Free inlet, Free outlet. Power rating (BHP) does not include transmission losses. Performance ratings include the effects of a birdscreen. The sound ratings shown are loudness values in hemispherical sones at 5 ft. (1.5 m) in a hemispherical free field calculated per AMCA Standard 301. Values shown are for installation type A: free inlet hemispherical sone levels.

Roof Downblast - Belt Drive GB-500

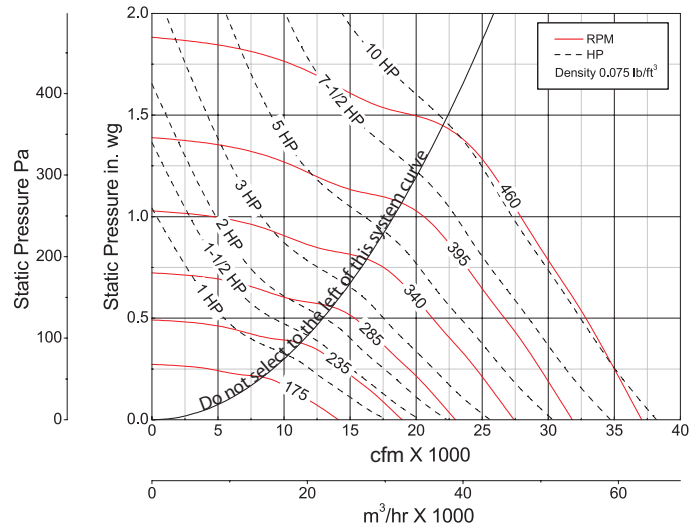
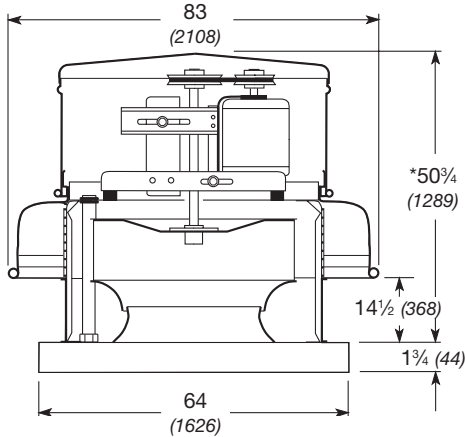

Damper Size = 54 x 54 (1371 x 1371)
 Roof Opening = 56½ x 56½ (1435 x 1435)
 Shroud Thickness = 0.100 (2.5)
 Motor Cover Thickness = 0.064 (1.6)
 Curb Cap Thickness = 0.100 (2.5)
 ^Approximate Unit Weight = 687 lb (312 kg)

All dimensions in inches (millimeters). *May be greater depending on motor.
 ^Weight shown is largest cataloged Open Drip-Proof motor.

Model Number	Motor HP	Fan RPM		Static Pressure in Inches wg											
				0	0.125	0.25	0.375	0.5	0.625	0.75	0.875	1	1.25		
500-10	1	175	CFM	14102	11123										
			BHP	0.50	0.57										
			Sones	6.7	6.5										
		200	CFM	16117	13588	10593									
			BHP	0.75	0.85	0.83									
			Sones	8.4	8.0	7.7									
214	CFM	17245	14939	12242											
	BHP	0.92	1.04	1.04											
	Sones	9.5	9.1	8.7											
500-15	1½	245	CFM	19743	17749	15481	12983								
			BHP	1.38	1.54	1.57	1.53								
			Sones	11.9	11.5	11.0	10.7								
500-20	2	269	CFM	21677	19873	17857	15752								
			BHP	1.83	2.02	2.06	2.08								
			Sones	14.0	13.8	13.2	12.7								
500-30	3	308	CFM	24820	23263	21627	19752	17903	15284						
			BHP	2.74	3.00	3.09	3.11	3.11	2.96						
			Sones	17.7	17.4	16.9	16.2	15.8	15.6						
500-50	5	337	CFM	27157	25739	24253	22614	20937	19206	16671					
			BHP	3.59	3.89	4.01	4.06	4.08	4.06	3.88					
			Sones	19.9	19.5	19.1	18.5	17.9	17.6	17.4					
		366	CFM	29494	28188	26834	25429	23831	22310	20688	18366				
			BHP	4.60	4.92	5.10	5.20	5.20	5.24	5.19	4.99				
			Sones	22	22	21	21	20	19.8	19.5	19.4				
500-75	7½	419	CFM	33764	32624	31467	30265	29015	27607	26276	24940	23486			
			BHP	6.90	7.27	7.57	7.70	7.80	7.80	7.84	7.88	7.78			
			Sones	27	27	27	26	26	25	24	24	23			
500-100	10	440	CFM	35457	34371	33279	32134	30989	29679	28373	27107	25801	22407		
			BHP	8.00	8.38	8.74	8.87	9.01	9.03	9.05	9.10	9.09	8.73		
			Sones	30	29	29	29	29	28	27	26	26	25		
		460	CFM	37068	36030	34991	33900	32805	31625	30342	29127	27917	25310		
			BHP	9.14	9.54	9.94	10.10	10.24	10.32	10.32	10.36	10.41	10.26		
			Sones	32	32	32	32	32	32	31	30	29	28	27	

Performance certified is for installation type A: Free inlet, Free outlet. Power rating (BHP) does not include transmission losses. Performance ratings include the effects of a birdscreen. The sound ratings shown are loudness values in loudness sones at 5 ft. (1.5 m) in a hemispherical free field calculated per AMCA Standard 301. Values shown are for installation type A: free inlet hemispherical sone levels.

Roof Downblast - Belt Drive GB-540

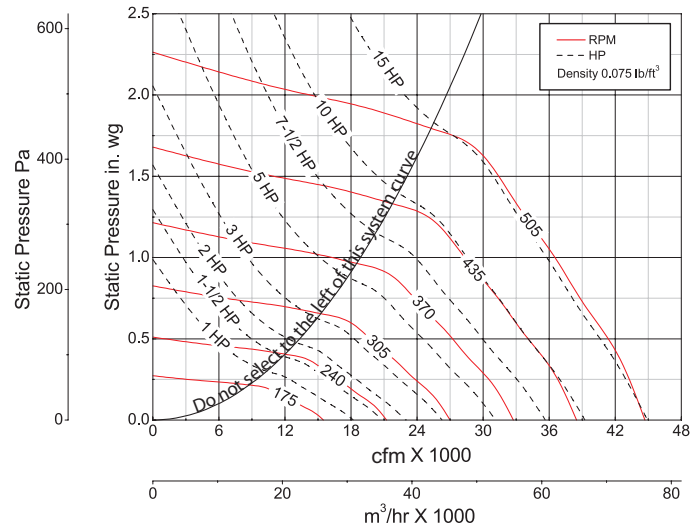
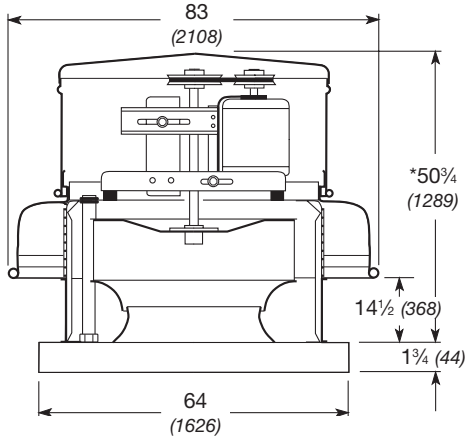

Damper Size = 54 x 54 (1371 x 1371)
 Roof Opening = $56\frac{1}{2} \times 56\frac{1}{2}$ (1435 x 1435)
 Shroud Thickness = 0.100 (2.5)
 Motor Cover Thickness = 0.064 (1.6)
 Curb Cap Thickness = 0.100 (2.5)
 ^Approximate Unit Weight = 748 lb (339 kg)

All dimensions in inches (millimeters). *May be greater depending on motor.
 ^Weight shown is largest cataloged Open Drip-Proof motor.

Model Number	Motor HP	Fan RPM		Static Pressure in Inches wg																	
				0	0.125	0.25	0.375	0.5	0.75	1	1.25	1.5	1.75								
540-10	1	175	CFM	15488	1250																
			BHP	0.61	0.65																
			Sones	6.9	6.3																
		195	CFM	17258	14674	11068															
			BHP	0.85	0.90	0.87															
			Sones	7.8	7.5	7.2															
205	CFM	18143	15724	12632																	
	BHP	0.99	1.04	1.03																	
	Sones	8.3	8.2	8.1																	
540-15	1 1/2	235	CFM	20798	18814	16229	12673														
			BHP	1.49	1.57	1.56	1.50														
			Sones	10.1	10.4	10.5	10.6														
540-20	2	259	CFM	22922	21228	18963	16439														
			BHP	1.99	2.09	2.11	2.08														
			Sones	12.3	12.1	11.9	11.6														
540-30	3	296	CFM	26197	24874	22870	20831	18610													
			BHP	2.97	3.11	3.14	3.13	3.10													
			Sones	16.2	15.6	15.3	15.0	14.3													
540-50	5	351	CFM	31064	30005	28492	26810	25115	21376												
			BHP	4.96	5.13	5.21	5.24	5.23	5.15												
			Sones	21	21	19.9	19.3	18.7	17.4												
540-75	7 1/2	402	CFM	35578	34653	33552	32075	30612	27519	24274											
			BHP	7.45	7.65	7.80	7.84	7.87	7.82	7.73											
			Sones	27	26	26	25	24	23	21											
540-100	10	442	CFM	39118	38277	37435	36109	34766	32131	29134	26111										
			BHP	9.90	10.12	10.34	10.39	10.44	10.46	10.36	10.24										
			Sones	32	32	32	32	32	28	27	26										
540-150	15	474	CFM	41950	41165	40381	39287	38034	35558	32927	30151	26271									
			BHP	12.21	12.45	12.68	12.80	12.85	12.90	12.84	12.73	12.42									
			Sones	36	36	37	36	35	33	31	30	28									
		505	CFM	44694	43957	43221	42332	41157	38813	36503	33869	31293	26758								
			BHP	14.77	15.02	15.27	15.45	15.51	15.60	15.60	15.48	15.36	14.84								
			Sones	40	40	40	40	39	38	36	35	32	30								

Performance certified is for installation type A: Free inlet, Free outlet. Power rating (BHP) does not include transmission losses. Performance ratings include the effects of a birdscreen. The sound ratings shown are loudness values in hemispherical sones at 5 ft. (1.5 m) in a hemispherical free field calculated per AMCA Standard 301. Values shown are for installation type A: free inlet hemispherical sone levels.

Belt Drive Specifications

Model GB

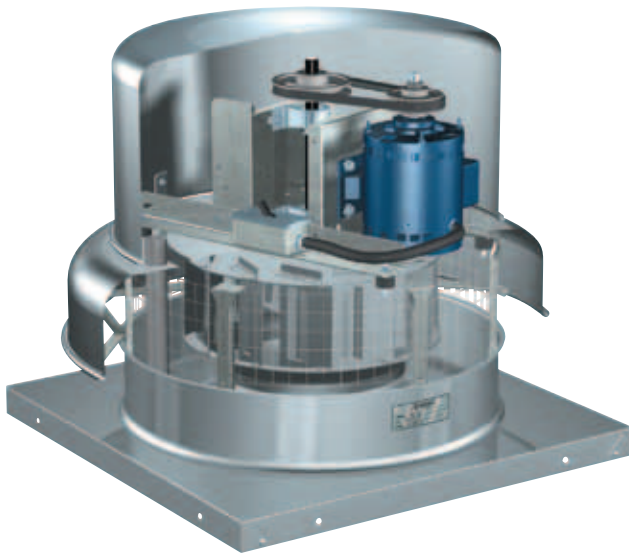

Spun aluminum downblast exhaust fans shall be belt drive-type. These fans are specifically designed for roof mounted applications exhausting relatively clean air. Performance capabilities range up to 44,700 cfm (75,946 m³/hr) and 2.5 in. wg (623 Pa) of static pressure. The maximum continuous operating temperature shall be 180°F (82°C). Model GB fans are available in twenty sizes with nominal wheel diameters ranging from 11 to 54 inches (279 to 1372 mm) (071-540 unit sizes).

Each fan shall bear a permanently affixed manufacturer's engraved metal nameplate containing the model number and individual serial number.

All fans shall bear the AMCA Sound and Air Performance seal.

The fan wheel shall be centrifugal non-overloading backward-inclined, constructed of aluminum and shall include a wheel cone carefully matched to the inlet cone for precise running tolerances. Wheels shall be statically and dynamically balanced in accordance to AMCA Standard 204-05.

Motors shall be heavy-duty ball bearing-type, carefully matched to the fan load and furnished at the specified voltage, phase and enclosure. Drives shall be sized for a minimum of 150% of driven horsepower. Motors and drives shall be mounted on true vibration isolators, out of the airstream. Fresh air for motor cooling shall be drawn into the motor compartment from an area free of discharge contaminants. Motors shall be readily accessible for maintenance. True vibration isolators shall be

double-studded or pedestal mount with no metal to metal contact. Each vibration isolator shall be sized to match the weight of each fan.

Fan shafts shall be precision ground and polished solid steel with an anti-corrosive coating. Fan shafts shall be mounted in permanently sealed, lubricated pillow block ball bearings. The first critical speed on a fan shaft shall be at least 25 percent over maximum operating speed. Bearings shall be selected for a minimum L₁₀ life in excess of 100,000 hours (L₅₀ life of 500,000 hours) at maximum cataloged operating speed. All bearings are 100 percent factory tested.

The fan housing shall consist of the motor cover, shroud, curb cap and lower windband, and shall be constructed of heavy-gauge aluminum. Housing shall have a rigid internal support structure and leakproof design. The fan shroud shall be one-piece with a rolled bead for extra strength which directs exhaust air downward. The lower windband shall be one-piece with formed edges for added strength and the curb cap shall include prepunched mounting holes to ensure correct attachment to the roof.

Drive frame assemblies shall be constructed of heavy-gauge steel and mounted on true vibration isolators. Pulleys shall be of the fully machined cast iron-type, keyed and securely attached to the wheel and motor shafts. Motor pulleys shall be adjustable for final system balancing.

A disconnect switch is a positive electrical shutoff and shall be wired from the fan motor to a junction box installed within the motor compartment. Factory standard shall be a NEMA-1 disconnect switch with other NEMA rated options also available. Disconnect switches shall be factory mounted and/or shipped loose for field mounting.

Options and accessories shall include: auto belt tensioner, curb extension, curb seal, dampers, coatings, hinge kit, hinge base, pressure probe, roof curbs, and tie-down points.

Fans shall be model GB as manufactured by Greenheck Fan Corporation of Schofield, Wisconsin, USA.

High Wind and Hurricane Belt Drive Specifications

Model GB

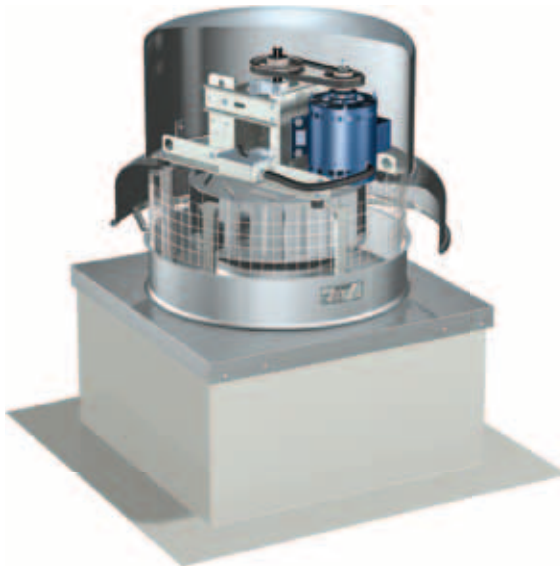

Spun aluminum downblast exhaust fans shall be belt drive-type. These fans are specifically designed for roof mounted applications exhausting relatively clean air. Performance capabilities range up to 44,700 cfm (75,946 m³/hr) and 2.5 in. wg (623 Pa) of static pressure. The maximum continuous operating temperature shall be 180°F (82°C). Model GB fans are available in twenty sizes with nominal wheel diameters ranging from 11 to 54 inches (279 to 1372 mm) (071-540 unit sizes).

Each fan shall bear a permanently affixed manufacturer's engraved metal nameplate containing the model number and individual serial number.

All fans shall bear the AMCA Sound and Air Performance seal.

The fan wheel shall be centrifugal non-overloading backward-inclined, constructed of aluminum and shall include a wheel cone carefully matched to the inlet cone for precise running tolerances. Wheels shall be statically and dynamically balanced in accordance to AMCA Standard 204-05.

Motors shall be heavy-duty ball bearing-type, carefully matched to the fan load and furnished at the specified voltage, phase and enclosure. Drives shall be sized for a minimum of 150% of driven horsepower. Motors and drives shall be mounted on true vibration isolators, out of the airstream. Fresh air for motor cooling shall be drawn into the motor compartment from an area free of discharge contaminants. Motors shall be readily accessible for maintenance. True vibration isolators shall be double-studded or pedestal mount with no metal to metal contact. Each vibration isolator shall be sized to match the weight of each fan.

Fan shafts shall be precision ground and polished solid steel with an anti-corrosive coating. Fan shafts shall be mounted in permanently sealed,

lubricated pillow block ball bearings. The first critical speed on a fan shaft shall be at least 25 percent over maximum operating speed. Bearings shall be selected for a minimum L₁₀ life in excess of 100,000 hours (L₅₀ life of 500,000 hours) at maximum cataloged operating speed. All bearings are 100 percent factory tested.

The fan housing shall consist of the motor cover, shroud, curb cap and lower windband, and shall be constructed of heavy-gauge aluminum. Housing shall have a rigid internal support structure and leakproof design. The fan shroud shall be one-piece with a rolled bead for extra strength which directs exhaust air downward. The lower windband shall be one-piece with formed edges for added strength and the curb cap shall include prepunched mounting holes to ensure correct attachment to the roof.

Drive frame assemblies shall be constructed of heavy-gauge steel and mounted on true vibration isolators. Pulleys shall be of the fully machined cast iron-type, keyed and securely attached to the wheel and motor shafts. Motor pulleys shall be adjustable for final system balancing.

A disconnect switch is a positive electrical shutoff and shall be wired from the fan motor to a junction box installed within the motor compartment. Factory standard shall be a NEMA-1 disconnect switch with other NEMA rated options also available. Disconnect switches shall be factory mounted and/or shipped loose for field mounting.

Fans shall meet all Greenheck wind load standards and shall contain the following third-party certifications:

- Miami-Dade NOA# 08-0519.02
- Licensed P.E. calculations shall be available for fan per ASCE 7-02 Minimum Design Loads for Buildings and Other Structures for exposure Class C, 60 foot building height, and a type II building.
- Fan shall be tested in accordance with ASTM E-330-02 Structural Performance of Exterior Windows, Doors, Skylights and Curtain Walls by Uniform Static Air Pressure Difference and Florida Building Code Test Protocol TAS-201, 202 and 203 at the ASCE 7-02 calculated design pressure.
- Licensed P.E. calculations for attachment of fan to curb shall be available for ASCE 7-02 determined design pressure.
- All calculations and testing shall be done by a state licensed P.E., and a certified test lab.

Fans shall be Greenheck models GB or GB-HP with high wind resistant construction option and manufactured by Greenheck Fan Corporation in Schofield, Wisconsin.