

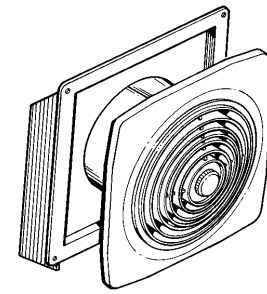

SPECIFICATION SHEET

MODELS 508 & 509 UTILITY WALL VENTILATION FANS



Efficient ventilation for a variety of applications.

FEATURES

GRILLE:

- Contemporary styled grille complements modern decor
- White polymeric grille can be painted to match any decor
- Aluminum filter available - purchase separately

MOTOR:

- Permanently lubricated, thermally protected, plug-in motor
- Motor assembly offers fast, easy "twist-lock" installation
- Specially designed polymeric fan blade
- Model 508 - 10" (254 mm) diameter fan blade, Model 505 - 8" (203.2 mm) diameter fan blade

HOUSING:

- Housing adjusts to fit walls from 4 1/2" (114.3 mm) to 9 1/2" (241.3 mm) thick
- Rugged steel housing with a modern profile
- Long-lasting electrically-bonded epoxy coating can be painted to match outdoor styling
- Built-in back-draft damper

TYPICAL SPECIFICATION

Ventilator shall be Broan Model 508 or (509).

Ventilator shall duct directly through an outside wall from 4 1/2" (114.3 mm) to 9 1/2" (241.3 mm) thick. Unit shall be controlled with a toggle switch.

Ventilator shall be steel housing finished in black electrically bonded epoxy paint. Grille to be white polymeric.

Motor assembly shall be removable and permanently lubricated.

Model 509 is CSA certified for kitchen use when used with aluminum filter - Model number 99010042 (purchase separately).

Air delivery shall be no less than 270 CFM (127.4 L/s) and sound levels no greater than 6.0 Sones (Model 508), 180 CFM (85.0 L/s) and 6.5 Sones (Model 509). All air and sound ratings shall be certified by HVI. Units shall be CSA certified.

SPECIFICATIONS

| MODEL | VOLTS | AMPS | RPM | SONES | CFM (L/s) | DUCT (Round) |
|-------|-------|------|------|-------|-------------|--------------|
| 508 | 120 | 1.7 | 1625 | 6.0 | 270 (127.4) | 10" (254mm) |
| 509 | 120 | 1.5 | 1925 | 6.5 | 180 (85.0) | 8" (203.2mm) |

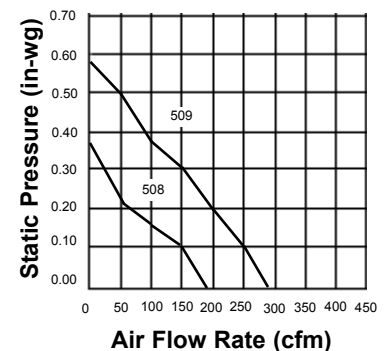
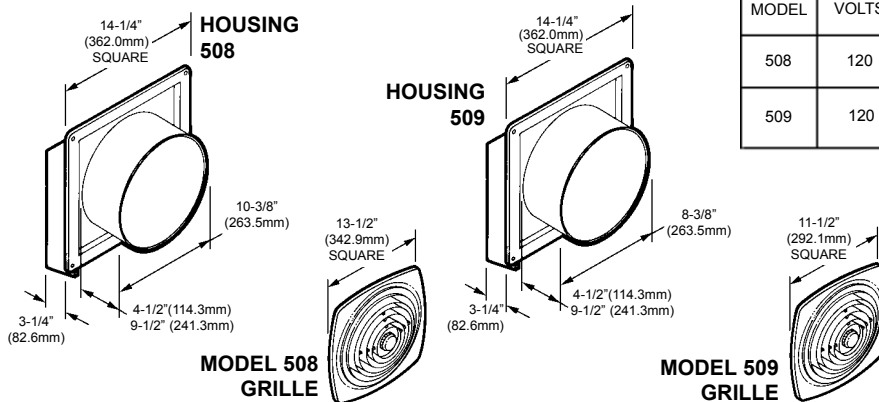

HVI-2100 CERTIFIED RATINGS comply with the new testing technologies and procedures prescribed by the Home Ventilating Institute, for off-the-shelf products, as they are available to consumers. Product performance is rated at 0.1 in. static pressure, based on tests conducted in AMCA's state-of-the-art laboratory. Sones are a measure of humanly produced loudness, based on laboratory measurements.



Broan-NuTone LLC, Hartford, Wisconsin, U.S.A. 53027
Broan-NuTone Canada Inc., Mississauga, Ontario, Canada L5T 1H9

| REFERENCE | QTY. | REMARKS | Project |
|-----------|------|---------|--------------|
| | | | Location |
| | | | Architect |
| | | | Engineer |
| | | | Contractor |
| | | | Submitted by |
| | | | Date |