

MODEL 512 UTILITY ROOM TO ROOM VENTILATION FAN

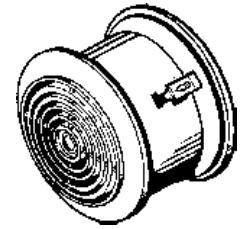

Move heated or cooled air through interior walls with this small, yet powerful unit

FEATURES

GRILLE:

- White polymeric - complements any decor
- Spin-on mounting

MOTOR:

- Plug-in, thermally protected, permanently lubricated
- Quiet, polymeric blade

HOUSING:

- 24 gauge steel housing finished with electrically bonded epoxy paint
- Fits walls up to 5 1/8" (130 mm) thick

TYPICAL SPECIFICATION

Ventilator shall be Broan Model 512.

Unit shall be installed in an interior wall - NOT through a fire wall. Unit shall be controlled with a toggle switch (speed control) or a timer, which may be purchased separately.

Ventilator shall have steel housing finished with electrically-bonded epoxy paint.

Motor assembly shall be removable and permanently lubricated.

Air delivery shall be no less than 90 CFM (42.2 L/s) and sound level no greater than 3.5 Sones. All air and sound ratings shall be certified by HVI. Unit shall be CSA certified.

SPECIFICATIONS

MODEL	VOLTS	AMPS	RPM	SONES	CFM (L/s)
512	120	0.5	2600	3.5	90 (42.5)

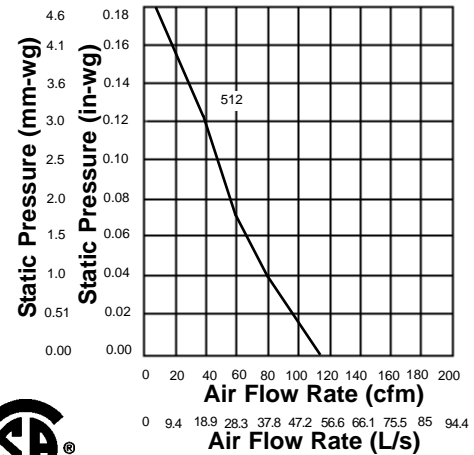
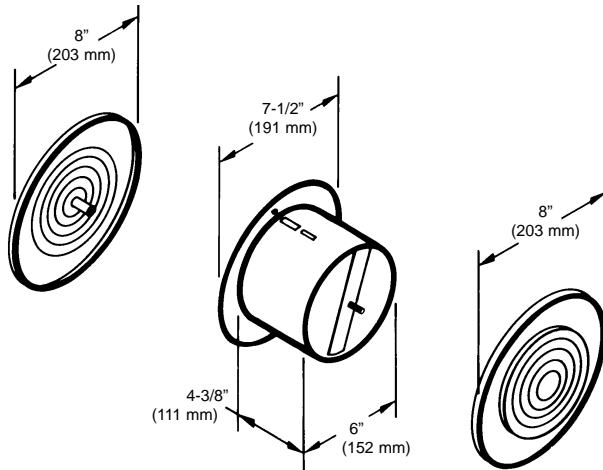

HVI-2100 CERTIFIED RATINGS comply with new testing technologies and procedures prescribed by the Home Ventilating Institute, for off-the-shelf products, as they are available to consumers. Product performance is rated at 0.1 in. (2.54 mm) static pressure, based on tests conducted in AMCA's state-of-the-art test laboratory. Sones are a measure of humanly-perceived loudness, based on laboratory measurements.



Broan-NuTone LLC, 926 West State Street, Hartford, WI 53027 (1-800-637-1453)
Broan-NuTone Canada Inc., 1140 Tristar Drive, Mississauga, Ontario, Canada L5T 1H9 (1-888-882-7626)

REFERENCE	QTY.	REMARKS	Project
			Location
			Architect
			Engineer
			Contractor
			Submitted by Date