

MODEL 683C VENTILATION FAN

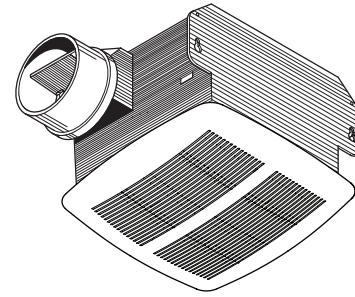

Quiet ventilator built with high performance blower and attractive grille.

FEATURES

GRILLE:

- Engineered resin construction
- Low-profile blends well with any decor
- Torsion spring grille mounting - no tools required

BLOWER:

- Plug-in, permanently lubricated motor
- Designed for continuous operation

HOUSING:

- Rugged, 26-gage galvanized steel construction
- Integral key-holed mounting brackets for easy, secure installation directly to joist
- Provision for wire suspension when installed in a drop ceiling
- 4-inch round, tapered, polymeric duct fitting with built-in backdraft damper for easy, positive duct connection and no metallic clatter

U.L. Listed for use over bathtubs and showers when connected to a GFCI protected branch circuit

SPECIFICATIONS

MODEL	VOLTS	AMPS	SONES	CFM	DUCT
683C	120	0.6	2.5	80	4" Round



HVI-2100 CERTIFIED RATINGS comply with new testing technologies and procedures prescribed by the Home Ventilating Institute, for off-the-shelf products, as they are available to consumers. Product performance is rated at 0.1 in. static pressure, based on tests conducted in AMCA's state-of-the-art test laboratory. Sones are a measure of humanly-perceived loudness, based on laboratory measurements.



TYPICAL SPECIFICATION

Fan shall be Broan Model 683C.

Unit shall have galvanized steel housing with integral mounting brackets. Unit shall have built-in backdraft damper and shall be ducted to a roof or wall cap.

Motor to be permanently lubricated and designed for continuous operation.

Air delivery shall be no less than 80 cfm and sound level no greater than 2.5 sones. All air and sound ratings shall be certified by HVI.

Unit shall be U.L. Listed for use over bathtubs and showers when connected to GFCI protected branch circuit.

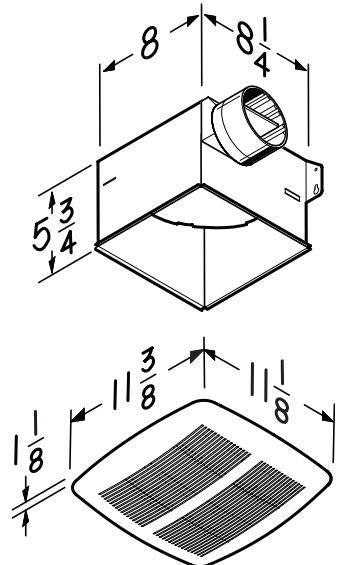

James Electric